



Sensor profiles SP for DIY installation without tools



EN | Product information

Mayser GmbH & Co. KG

Örlinger Straße 1-3

89073 Ulm

GERMANY

Phone: +49 731 2061-0

Fax: +49 731 2061-222

E-mail: info.ulm@mayser.com

Internet: www.mayser.com

Content

Overview	4
Materials list	5
Definitions	7
Pressure-sensitive protection device	7
Operation principle 2-wire-technology	8
Operation principle 4-wire-technology	9
Safety	11
Intended use	11
Limits	11
Exclusions	11
Other safety aspects	12
Design	12
Effective actuation area	13
Installation position	13
Connection	14
Cable exits	14
Cable connection	15
Wire colours.....	15
Connection examples	15
Sensor surface	16
Resistances.....	16
Attachment	18
Aluminium profiles:	
Overview of combinations.....	18
Aluminium profiles: Mounting types.....	19
Aluminium profile: Dimensions	20
SP: The right selection	22
Calculation for selection of the safety edge height	22
Calculation examples	22
Maintenance and cleaning	24
Technical data	25
SK SP 17-3 TPE.....	25
SK SP 37-1 TPE.....	27
SK SP 37(L)-2 TPE.....	29
SK SP 37-3 TPE.....	31
SK SP 57(L)-2 TPE.....	33
SK SP 57-3 TPE.....	35

Copyright

The reproduction, distribution and utilization of this document as well as the communication of its contents without express authorization are prohibited. Offenders will be held liable for the payment of damages. All rights reserved in the event of the grant of a patent, utility model or design.

© Maysers Ulm 2021

SK SP 57(L)-4 TPE.....	37
SK SP 67-2 TPE.....	39
SK SP 87-2 TPE.....	41
Marking.....	43
Conformity.....	43
EC design test.....	43
UL certification.....	43

Overview

Contact profile – Sensor profile

The semi-finished contact profile (Pos. 3) is cut to length and assembled with the other components. The functioning product is then called a sensor profile.

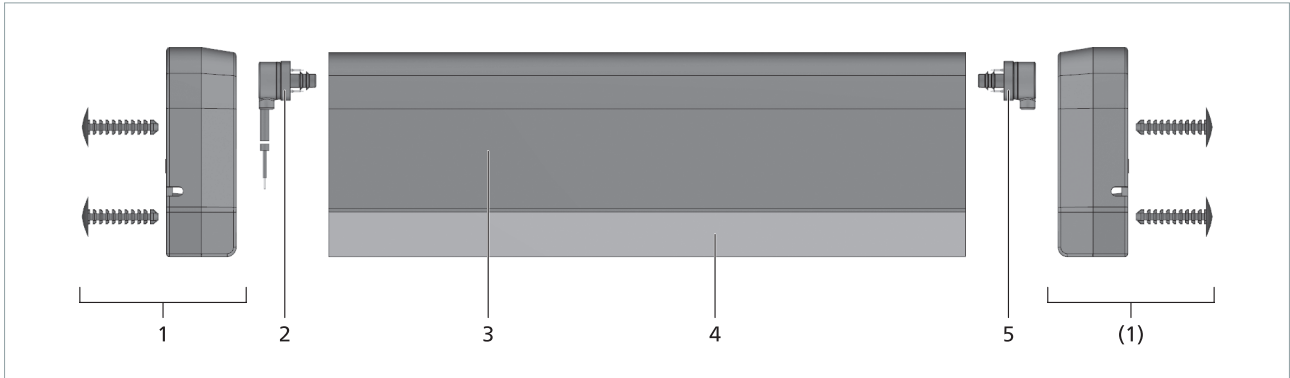

Positions 2 and 5 are identical for all sensor profiles.

Pos. 2	Closing plug with cable 2.5 m	7504038
Pos. 5	Closing plug with resistor	7504039

Alternatives for position 2 are:

Closing plug with cable 5.0 m	7504103
Closing plug with cable 10 m	7504102

Sensor profile	Pos. 1 Set of end caps	Pos. 3 Contact profile	Pos. 4 Aluminium profile
SP 17-3 without end caps	1005786	SP 17-3 7503461	C 15 1000016
SP 37-1 without end caps	1000606	SP 37-1 7502853	C 25 1000004
SP 37-1 with end caps	7503008	SP 37-1 7502853	C 25 1000004
SP 37-2 with end caps	7503988	SP 37-2 7503318	C 26 1004330
SP 37L-2 with end caps	7503988	SP 37L-2 7504192	C 26 1004330
SP 37-3 with end caps	7503505 (7503654)	SP 37-3 7503343	C 25 1000004
SP 57-2 with end caps	7503603 (7503062)	SP 57-2 7503055	C 30 1005844
SP 57L-2 with end caps	7503603 (7503062)	SP 57L-2 7503412	C 30 1005844
SP 57-3 with end caps	7503618	SP 57-3 7503521	C 35 1000006

Subject to technical modifications.

Sensor profile	Pos. 1 Set of end caps	Pos. 3 Contact profile		Pos. 4 Aluminium profile	
SP 57-4 with end caps	7503618	SP 57-4	7503633	C 35	1000006
SP 57L-4 with end caps	7503618	SP 57L-4	7503711	C 35	1000006
SP 67-2 with end caps	7503655	SP 67-2	7503285	C 30	1005844
SP 87-2 with end caps	7504118	SP 87-2	7503722	C 36	1003848

Materials list

Part No.	Designation	PU
7503461	Contact profile SP 17-3 TPE	80 m
7502853	Contact profile SP 37-1 TPE	30 m
7503318	Contact profile SP 37-2 TPE	30 m
7504192	Contact profile SP 37L-2 TPE	30 m
7503343	Contact profile SP 37-3 TPE "black"	30 m
7503534	Contact profile SP 37-3 TPE "red"	30 m
7503055	Contact profile SP 57-2 TPE	30 m
7503412	Contact profile SP 57L-2 TPE	30 m
7503521	Contact profile SP 57-3 TPE	25 m
7503633	Contact profile SP 57-4 TPE	25 m
7503711	Contact profile SP 57L-4 TPE	25 m
7503285	Contact profile SP 67-2 TPE	30 m
7503722	Contact profile SP 87-2 TPE	25 m
7504039	Closing plug with resistor 8k2	10 pc.
7504038	Closing plug with PUR cable 2.5 m, angled 90°	10 pc.
7504103	Closing plug with PUR cable 5.0 m, angled 90°	10 pc.
7504102	Closing plug with PUR cable 10 m, angled 90°	10 pc.
7504101	Closing plug without resistor	10 pc.
1005786	Countersunk tapping screw 3.5x25 for SP 17-3	20 pc.
7503008	Set of end caps for SP 37-1: each containing 2 end caps, fixing stoppers and screw 3.9x25	10 pc.
7503988	Set of end caps for SP 37(L)-2: each containing 2 end caps and 4 pine tree clips	10 pc.
7503505	Set of end caps for SP 37-3 „black“: each containing 2 end caps and pine tree clip	10 pc.

Subject to technical modifications.

Part No.	Designation	PU
7503654	Set of end caps for SP 37-3 „red“: each containing 2 end caps and pine tree clip	10 pc.
7503062	Set of end caps for SP 57(L)-2: each containing 2 end caps and 4 screws 5×20	10 pc.
7503603	Set of end caps for SP 57(L)-2 with clip: each containing 2 end caps and 4 pine tree clips	10 pc.
7503618	Set of end caps for SP 57-3 and SP 57(L)-4: each containing 2 end caps and 6 pine tree clips	10 pc.
7503655	Set of end caps for SP 67-2: each containing 2 end caps and 4 pine tree clips	10 pc.
7504118	Set of end caps for SP 87-2: each containing 2 end caps and 8 pine tree clips	10 pc.
1000016	Aluminium profile C 15	6 m
1000854	Aluminium profile C 25M, upper section	6 m
1000855	Aluminium profile C 25M, lower section	6 m
1000829	Aluminium profile C 25L	6 m
1000012	Aluminium profile C 25S	6 m
1000004	Aluminium profile C 25	6 m
1004626	Aluminium profile C 26M, upper section	6 m
1004627	Aluminium profile C 26M, lower section	6 m
1004330	Aluminium profile C 26, perforated	6 m
1005844	Aluminium profile C 30	6 m
1001398	Aluminium profile C 35M, upper section	6 m
1001399	Aluminium profile C 35M, lower section	6 m
1000013	Aluminium profile C 35S	6m
1000006	Aluminium profile C 35	6 m
1004629	Aluminium profile C 36M, upper section	6 m
1004630	Aluminium profile C 36M, lower section	6 m
1003849	Aluminium profile C 36L, perforated	6 m
1003850	Aluminium profile C 36S, perforated	6 m
1003848	Aluminium profile C 36, perforated	6 m
1001223	End stopper for C 25M, for SP without end caps	1 pc.
1000606	End stopper for C 25 or C 25S, ffor SP without end caps	1 pc.
1005906	Scissors with stop, cutting length 87 mm	1 pc.

Subject to technical modifications.

Definitions

Pressure-sensitive protection device

A pressure-sensitive protection device consists of pressure-sensitive sensor(s), signal processing and output signal switching device(s). The control unit is made up of the signal processing and output signal switching device(s). The pressure-sensitive protection device is triggered when the sensor is activated.

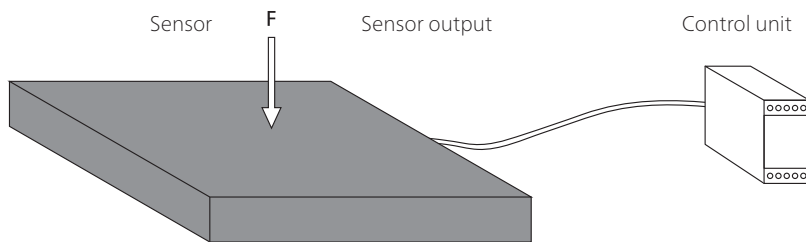

Sensor

The sensor is the part of the pressure-sensitive protection device that generates a signal when the actuating force F is applied. Mayser safety systems have a sensor whereby the actuating surface is deformed locally.

Signal processing

The signal processing is the part of the pressure-sensitive protection device that converts the output signal of the sensor and controls the status of the output signal switching device. The output signal switching device is that part of the signal processing which is connected to the machine controls and transmits safety output signals such as STOP.

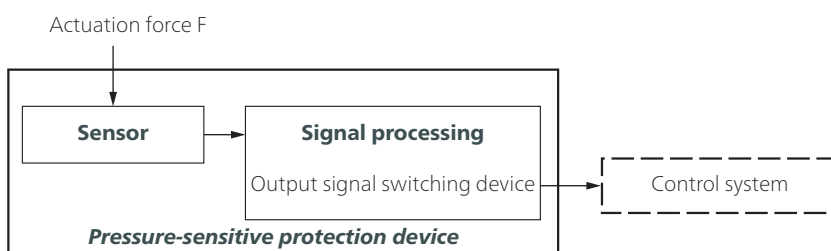

Tip: Terms are defined in ISO 13856-2, Chapter 3.

Criteria for selecting the sensor type

- Category according to ISO 13849-1
- Performance level of pressure-sensitive protection device = at least PL_r
- Temperature range
- Degree of protection in accordance with IEC 60529:
IP67 is the standard for safety edges.
Higher degrees of protection must be checked individually.
- Environmental influences such as swarf, oil, coolant, outdoor use...
- Finger detection necessary?

Operation principle 2-wire-technology

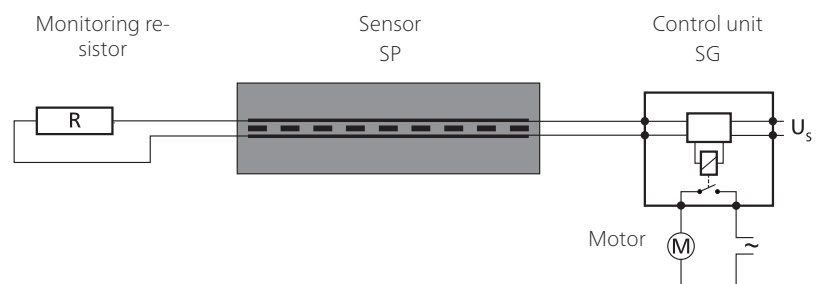

The monitoring resistor must be compatible with the control unit. Standard value is 8k Ω .

For your safety:

Sensor and connecting cables are constantly monitored for function. Monitoring is carried out by controlled bridging of the contact surfaces with a monitoring resistor (closed current principle).

Design

SP/BK with cables on both sides as a through sensor or as an end sensor with external monitoring resistor

SP/W as an end sensor with integrated monitoring resistor

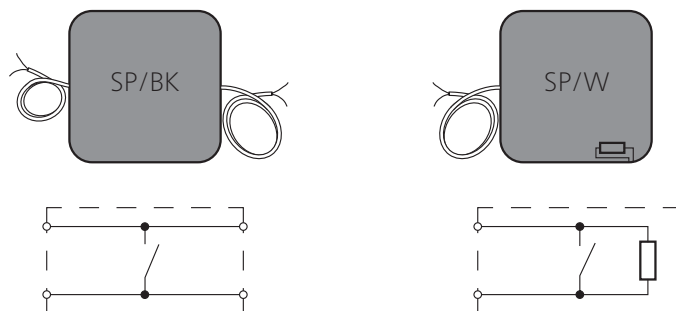

Subject to technical modifications.

Combination of sensors

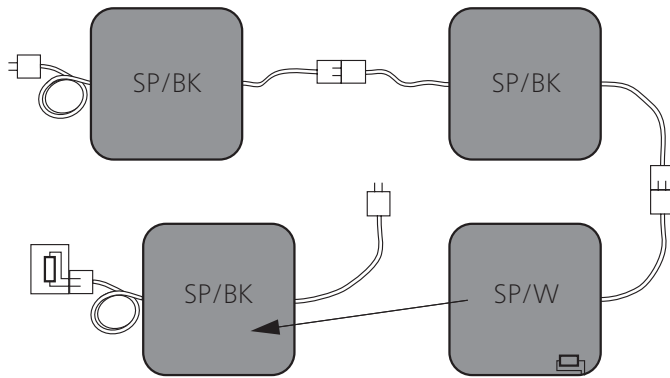

Model with external resistor, thus avoiding variety in type

Combination:

- Connection of more than one sensor
- Only one control unit required
- Safety edge design with custom lengths and angles

Operation principle 4-wire-technology

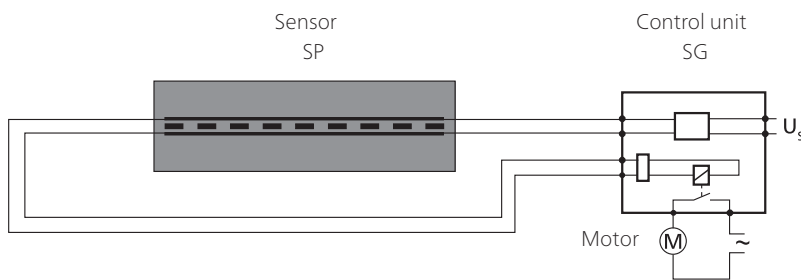

The 4-wire technology can be used only together with control unit SG-EFS 104/4L.

For your safety:

Sensor and connecting cables are constantly monitored for function. This is possible because of signal transmission feedback – without a monitoring resistor.

Design

SP/BK with cables on both sides as a through sensor



090221 v1.02-RIA

Subject to technical modifications.

Combination of sensors

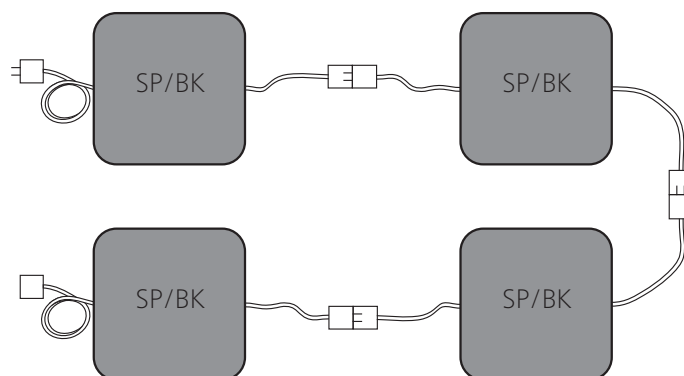

Combination:

- Connection of more than one sensor
- Only one control unit required
- Safety edge design with custom lengths and angles

Subject to technical modifications.

Safety

Intended use

A safety edge detects a person or part of the body when pressure is applied to the actuation area. It is a linear tripping device. Its task is to avoid possible hazardous situations for a person within a danger zone, such as shearing and pinching edges.

Typical areas of application are door and gate systems, moving parts on machines, platforms and lifting devices.

Safe operation of a safety edge depends entirely on

- the surface condition of the mounting surface,
- the correct selection of the size and resistance as well as
- correct installation.

For additional application guidelines refer to ISO 13856-2 Annex E.

Due to the design, the visible actuation area is reduced by the non-sensitive edges. What remains is the actual effective actuation area (see chapter *Effective actuation area*).

Limits

- max. 5 sensors type /BK on one control unit
- max. 4 sensors type /BK and 1 sensor type /W on one control unit

Exclusions

The sensors are not suitable for:

- performing a sealing function. Constant actuation of sensors can result in permanent damage.

Exception: The L version with an attached edge seal.

The edge seal can be in full contact with the closing edge, which allows it to repel wind and water.

Other safety aspects

The following safety aspects relate to pressure-sensitive protection devices consisting of a sensor and a control unit

Performance Level (PL)

The PL was determined during a procedure according to ISO 13849-1. Fault exclusion according to ISO 13849-2 Table D.8: Non-closing of contact by pressure-sensitive equipment according to ISO 13856. In this case the sensor will no longer be taken into account in determining the PL. The entire pressure sensitive safety edge (Pressure-sensitive protection device) system can reach a maximum of PL d.

Is the safeguard appropriate?

The PL required for the hazard must be decided by the integrator. This is followed by the choice of safeguard.

Finally, the integrator needs to check whether the category and PL of the safeguard chosen are appropriate.

Risk and safety assessment

For the risk and safety assessment of your machine we recommend ISO 12100 „Safety of machinery – general principles for design“.

Without reset function

When a safeguard without a reset function is used (automatic reset), the reset function must be made available in some other way.

Design

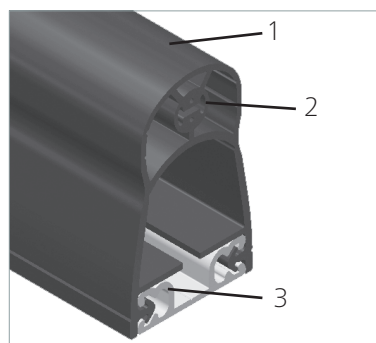

The sensor profile SP consists of one sensor (1 to 3)
(1) Contact profile SP with
(2) integrated normally open safety element,
(3) Aluminium profile and an evaluating control unit SG.

Subject to technical modifications.

Effective actuation area

The parameters X, Y, Z, L_{WB} and the angle α describe the effective actuation area.

For the effective actuation area, the following applies:

$$L_{WB} = L_{SP} - 2 \times L_{NE}$$

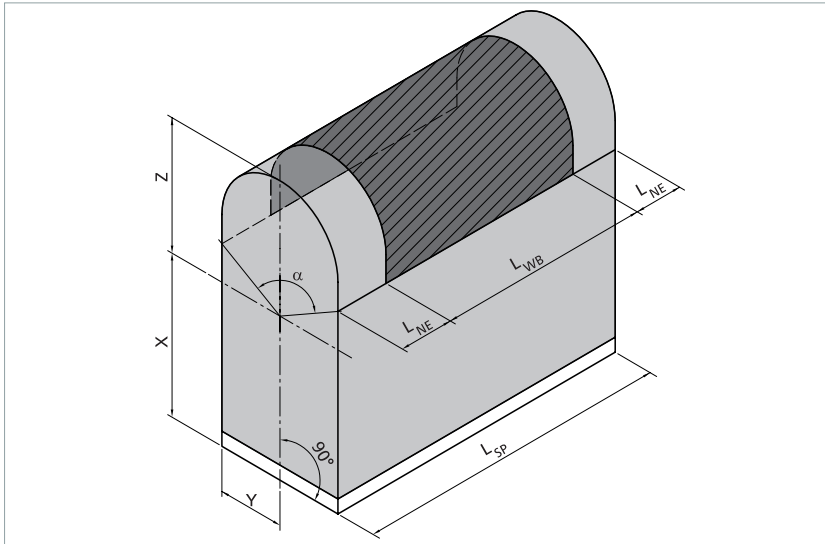

Parameters:

- L_{WB} = effective actuation length
- L_{SP} = total length of sensor profile
- L_{NE} = non-sensitive length at end of sensor profile
- α = effective actuation angle (Actuation angle)

	SP 17-3 ¹⁾	SP 37-1	SP 37(L)-2	SP 37-3	SP 57(L)-2	SP 57-3	SP 57(L)-4	SP 67-2	SP 87-2
Aluminium profile	C 15	C 25	C 26	C 25	C 30	C 35	C 35	C 30	C 36
α	90°	100°	100°	100°	90°	90°	90°	90°	90°
L_{NE}	60 mm	20 mm	20 mm	20 mm	10 mm ²⁾	10 mm ²⁾	10 mm ²⁾	20 mm ²⁾	10 mm ²⁾
Y	6.7 mm	12.5 mm	13 mm	12.5 mm	17 mm	17.5 mm	17.5 mm	17 mm	18.1 mm
X	15.3 mm	28.5 mm	30 mm	29 mm	44 mm	52 mm	52 mm	57.3 mm	72 mm
Z	5 mm	9 mm	9 mm ³⁾	9 mm	12 mm ³⁾	12 mm	12 mm ³⁾	10 mm	15 mm
X + Z	20.3 mm	37.5 mm	39 mm ³⁾	38 mm	56 mm ³⁾	64 mm	64 mm ³⁾	67.3 mm	87 mm

¹⁾ without end cap

²⁾ with finger protection

³⁾ without lip

Installation position

The installation position can be selected as required, i.e. all installation positions A to D as per ISO 13856-2 are possible.

Subject to technical modifications.

Connection

Cable exits

Depending on the end cap, the following cable exits are available.

- A_L = axial left
- A_M = axial middle
- A_R = axial right
- O_L = orthogonal left
- O_M = orthogonal middle
- O_R = orthogonal right

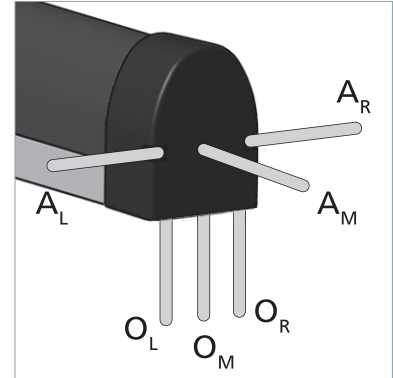

Orientation		Cable exit					
Lateral exit		A _L		A _R			
Axial exit			A _M				
90° exit					O _L	O _M	O _R
Combination							
Contact profile	Set of end caps						
SP 17-3	–		●			●	
SP 37-1	7503008	●		●	●		●
SP 37(L)-2	7503988	●	●	●		●	
SP 37-3 black	7503505	●		●	●		●
SP 37-3 red	7503654	●		●	●		●
SP 57(L)-2	7503062	●	●	●		●	
	7503603	●	●	●		●	
SP 57-3	7503618	●	●	●	●		●
SP 57(L)-4	7503796	●	●	●	●		●
SP 67-2	7503655	●	●	●		●	
SP 87-2	7504118	●	●	●		●	

● = possible

Cable connection

- Standard cable lengths
L = 2.5 m / 5.0 m / 10 m
- Maximum total cable length to the control unit
L_{max} = 100 m

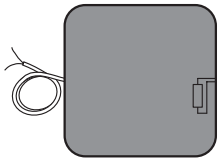
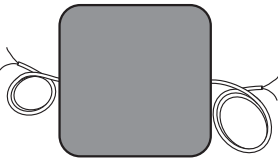
Sensor type /W with 1 line	Sensor type /BK with 2 lines
<ul style="list-style-type: none"> • As an individual sensor type /W or an end sensor type /W • Integrated resistor • 2-wire cable (Ø 2.9 mm PUR, 2x 0.25 mm² Cu) 	<ul style="list-style-type: none"> • As a feed-through sensor type /BK • Without resistor • 2 two-wire cables (Ø 2.9 mm PUR, 2x 0.25 mm² Cu)
	

Wire colours

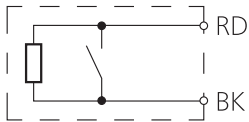
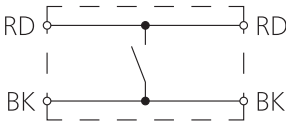
Sensor type /W with 1 line	Sensor type /BK with 2 lines
	

Colour coding

BK Black
RD Red

Connection examples

Legend:

SG 2W evaluation 2-wire technology

SG 4L evaluation 4-wire technology

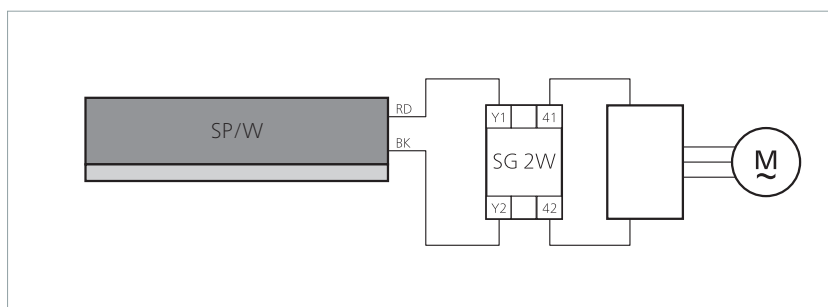

Subject to technical modifications.

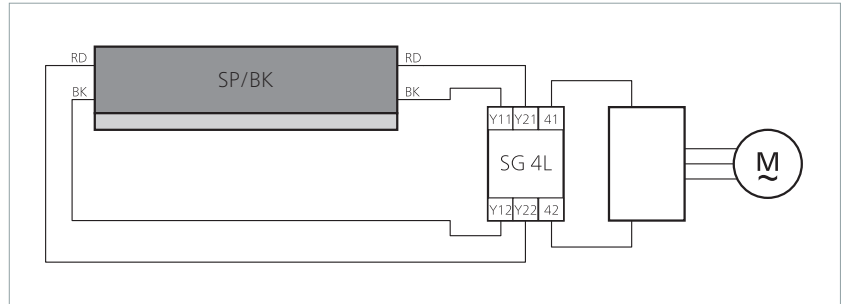

Sensor surface

Resistances

The resistance ratings listed below (at a room temperature of 23 °C) require a signal transmitter with an undamaged surface.

Physical resistance

	TPE
UV-resistance	yes

Chemical resistance

The sensor is resistant against normal chemical influences such as diluted acids and alkalis as well as alcohol over an exposure period of 24 hrs.

The specifications in the table are the result of tests conducted in our lab. The suitability of our products for your special area of application must always be verified with your own practical tests.

Subject to technical modifications.

Material	TPE
Acetone	-
Formic acid	-
Armor All	+
Car shampoo	+
Petrol	-
Brake fluid	+
Buraton	+
Butanol	-
Sodium hypochlorite	-
Disinfectant 1 %	+
Diesel	-
Acetic acid 10 %	-
Ethanol	+
Ethyl acetate	-
Ethylene glycol	+
Greases	±
Anti-frost agent	+
Skin cream	+
Icidine	+
Incidine	+
Incidine plus	+
Cooling lubricant	-
Plastic cleaner	+
Lyso FD 10	+
Metal working oil	-
Microbac	+
Microbac forte	+
Minutil	+
Saline solution 5 %	+
White spirit (ethyl alcohol)	+
Terralin	+
Centring oil	-

Explanation of symbols:

- + = resistant
- ± = resistant to a certain extent
- = not resistant

Attachment

The sensors are mounted directly on the hazardous main and secondary closing edges. Special aluminium profiles are used for mounting. The profiles are fastened with screws or rivets.

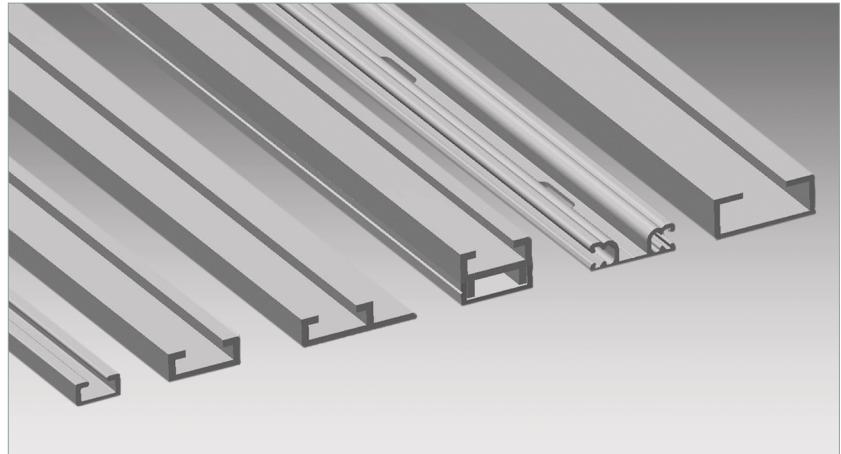





Material properties

- AlMgSi0.5 F22
- wall thickness at least 2.0 mm
- hot hardened
- extruded
- tolerances as per EN 755-9
- C 15: at least 1.7 mm
- C 30: at least 1.5 mm

Aluminium profiles:

Overview of combinations

Sensor profile foot		C 15	C 25 C 25M C 25S C 25L	C 26 C 26M	C 30	C 35 C 35M C 35S	C 36 C 36M C 36S C 36L
Snap-in foot (middle)	...-1 	–	SP 37-1	–	–	–	–
Clip bar (outside)	...-2 	–	–	SP 37(L)-2	SP 57(L)-2 SP 67-2	–	SP 87-2
T-foot (middle)	...-3 	SP 17-3	SP 37-3	–	–	SP 57-3	–
T-foot narrow (middle)	...-4 	–	–	–	–	SP 57(L)-4	–







090221 v1.02-RIA

Subject to technical modifications.

Aluminium profiles: Mounting types

Standard profile

First the aluminium profile must be mounted onto the closing edge and then the sensor profile clipped into the aluminium profile.

C 15	C 25	C 26	C 30	C 35	C 36
					

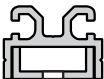
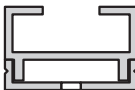
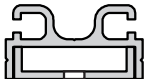

Two-part profile type M

For convenient assembly and disassembly. The sensor profile is clipped into the upper section and the upper section inserted into the installed lower section and fastened.

-	C 25M	C 26M	C 35M	C 36M
				

Flange profile type S

Final assembly is also possible when the sensor profile is already clipped into the aluminium profile.

-	C 25S	-	C 35S	C 36S
				

Angle profile type L

If the closing edge should or must not have assembly holes, this "round-the-corner" solution is suitable. Final assembly is also possible when the sensor profile is already clipped into the aluminium profile.

-	C 25L	-	-	C 36L
				

Aluminium profile: Dimensions

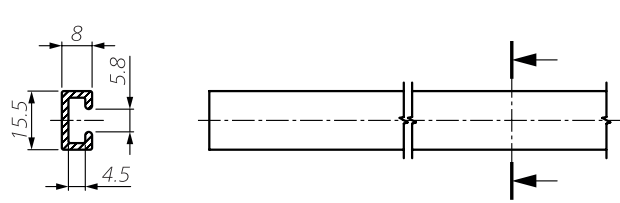
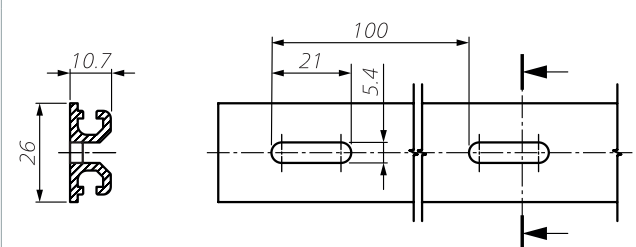
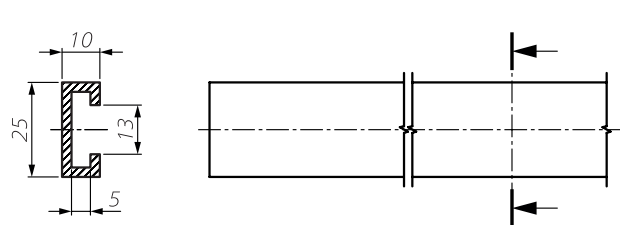
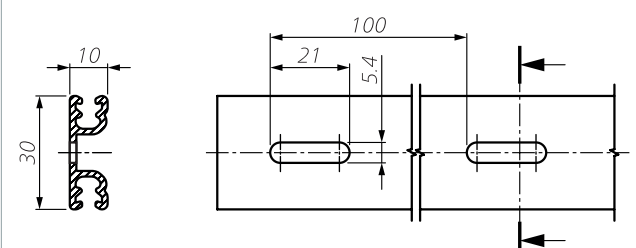
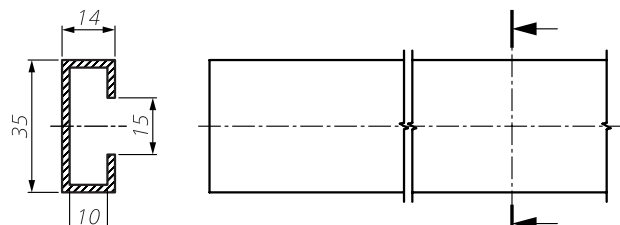
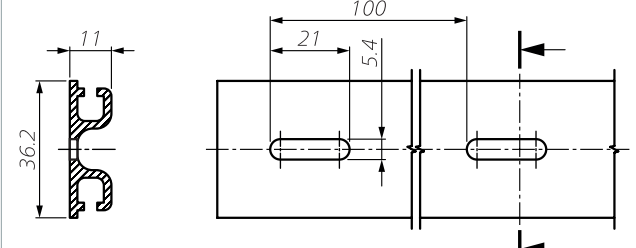
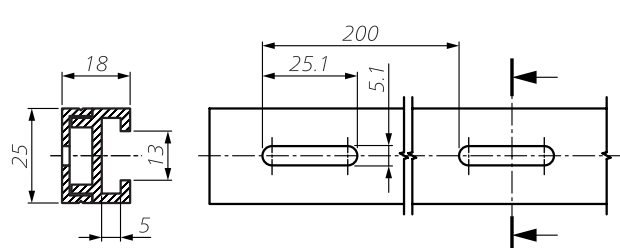
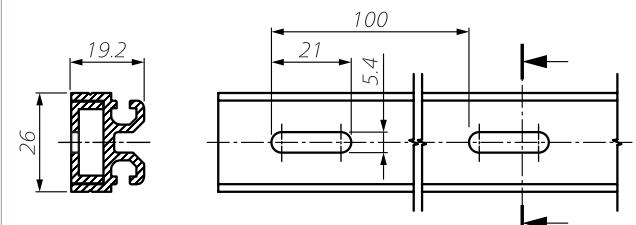
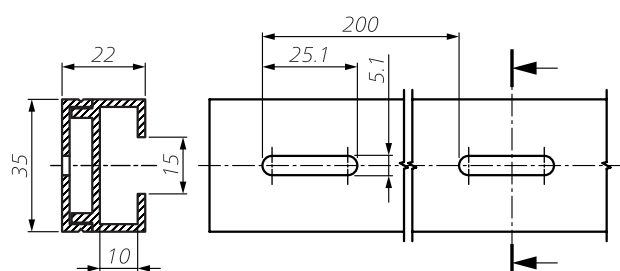
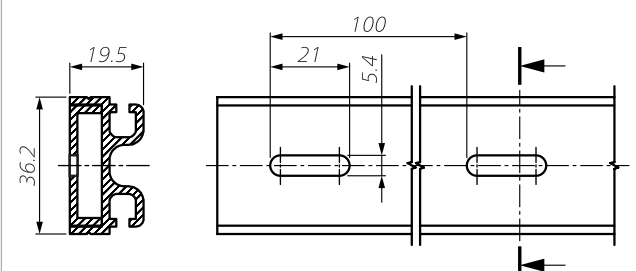
Standard profile		1:2
C 15		C 26 
C 25		C 30 
C 35		C 36 
Two-part profile type M		1:2
C 25M		C 26M 
C 35M		C 36M 

Subject to technical modifications.

Flange profile type S **1:2**

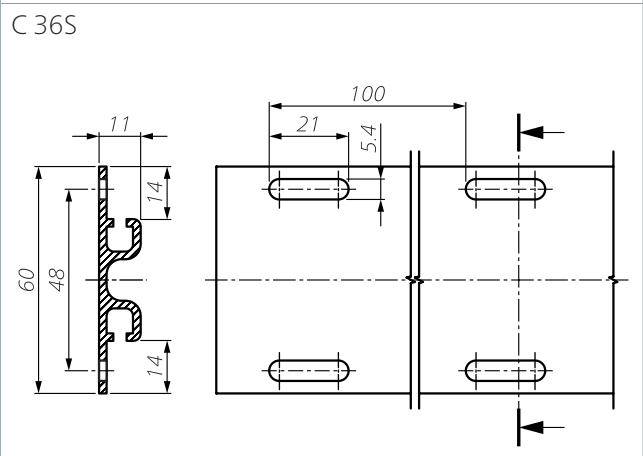
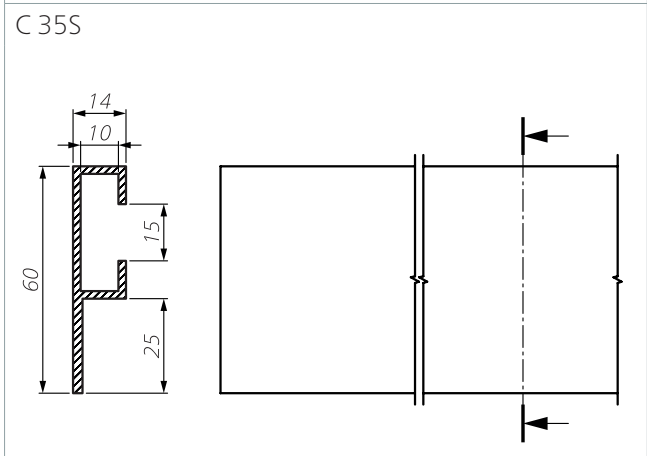
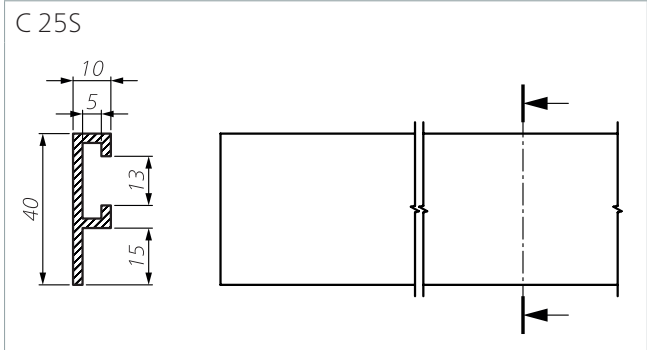

Angle profile type L **1:2**

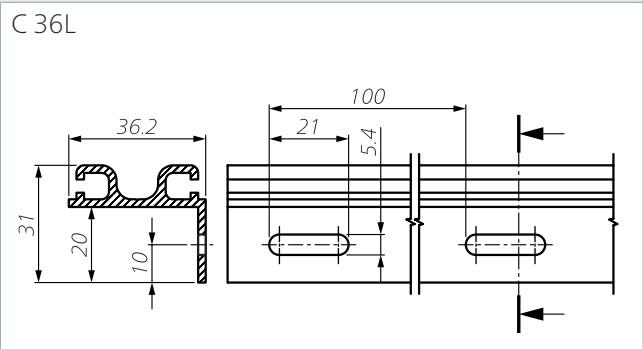
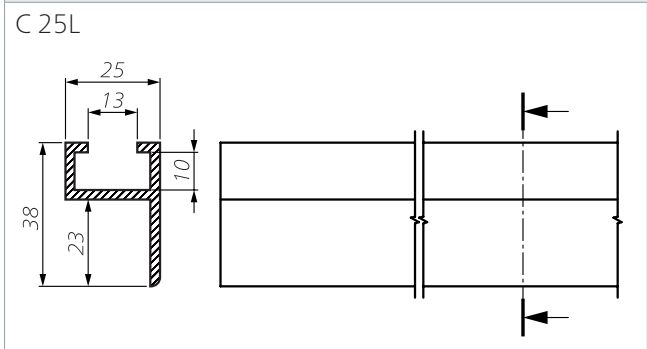

SP: The right selection

Calculation for selection of the safety

edge height

- s_1 = Stopping distance of the dangerous movement [mm]
- v = Velocity of the dangerous movement [mm/s]
- T = Follow-through of the complete system [s]
- t_1 = Response time safety edge
- t_2 = Stopping time of the machine
- s = Minimum overtravel distance of the safety edge so that the required limit forces are not exceeded [mm]
- C = Safety factor; if components susceptible to failures (braking system) exist in the system, a higher factor must be selected

The stopping distance of the dangerous movement is calculated using the following formula:

$$s_1 = 1/2 \times v \times T \text{ where: } T = t_1 + t_2$$

In accordance with ISO 13856-2, the minimum overtravel distance of the safety edge is calculated using the following formula:

$$s = s_1 \times C \quad \text{where: } C = 1,2$$

A suitable safety edge profile can now be selected based on the result. Overtravel distances of safety edge profiles: see chapter *Technical data*.

Calculation examples

Example 1

The dangerous movement on your machine has a velocity of $v = 10$ mm/s and can be brought to a standstill within $t_2 = 200$ ms. The relatively low velocity suggests that a short overtravel distance is to be expected. Therefore the sensor profile SP 37-1 TPE could be sufficient. The response time of the safety edge (SP 37-1 TPE + control unit*) is $t_1 = 600$ ms.

$$s_1 = 1/2 \times v \times T \quad \text{where: } T = t_1 + t_2$$

$$s_1 = 1/2 \times 10 \text{ mm/s} \times (0.6 \text{ s} + 0.2 \text{ s})$$

$$s_1 = 1/2 \times 10 \text{ mm/s} \times 0.8 \text{ s} = \mathbf{4.0 \text{ mm}}$$

$$s = s_1 \times C \quad \text{where: } C = 1.2$$

$$s = 4.0 \text{ mm} \times 1.2 = \mathbf{4.8 \text{ mm}}$$

The safety edge must have a minimum overtravel distance of $s = 4.8$ mm. The selected SP 37-1 TPE has an overtravel distance of at least 9.2 mm. This is more than the required 4.8 mm.

Result: The SP 37-1 TPE is **suitable** for this case.

Example 2

The same conditions as in calculation example 1 with the exception of the velocity of the dangerous movement. This is now $v = 200 \text{ mm/s}$. The response time of the safety edge (SP 37-1 TPE + control unit*) is $t_1 = 55 \text{ ms}$.

$$s_1 = 1/2 \times v \times T \quad \text{where: } T = t_1 + t_2$$

$$s_1 = 1/2 \times 200 \text{ mm/s} \times (0.055 \text{ s} + 0.2 \text{ s})$$

$$s_1 = 1/2 \times 200 \text{ mm/s} \times 0.255 \text{ s} = \mathbf{25.5 \text{ mm}}$$

$$s = s_1 \times C \quad \text{where: } C = 1.2$$

$$s = 25.5 \text{ mm} \times 1.2 = \mathbf{30.6 \text{ mm}}$$

The safety edge must have a minimum overtravel distance of $s = 30.6 \text{ mm}$. The selected SP 37-1 TPE has an overtravel distance of at least 3.8 mm . This is less than the required 30.6 mm .

Result: The SP 37-1 TPE is **not suitable** for this case.

Example 3

The same conditions as in calculation example 2. Instead of SP 37-1 EPDM the SP 67-1 TPE is selected. The response time of the safety edge (SP 67-2 TPE + control unit*) is $t_1 = 72 \text{ ms}$.

$$s_1 = 1/2 \times v \times T \quad \text{where: } T = t_1 + t_2$$

$$s_1 = 1/2 \times 200 \text{ mm/s} \times (0.072 \text{ s} + 0.2 \text{ s})$$

$$s_1 = 1/2 \times 200 \text{ mm/s} \times 0.272 \text{ s} = \mathbf{27.2 \text{ mm}}$$

$$s = s_1 \times C \quad \text{where: } C = 1.2$$

$$s = 27.2 \text{ mm} \times 1.2 = \mathbf{32.6 \text{ mm}}$$

The safety edge must have a minimum overtravel distance of $s = 32.6 \text{ mm}$. The selected SP 67-2 TPE has an overtravel distance of at least 36.5 mm . This is more than the required 32.6 mm .

Result: The SP 67-2 TPE is **suitable** for this case.

* Assumption: Typical reaction time of a control unit = 20 ms

Subject to technical modifications.

Maintenance and cleaning

The sensors are virtually maintenance-free.
The control unit also monitors the sensor.

Regular inspection

Depending on the utilisation, sensors must be inspected at regular intervals (at least monthly)

- for proper functioning,
- damage,
- and correct mounting.

Cleaning

If the sensors become dirty, they can be cleaned with a mild cleaning product.

Technical data

SK SP 17-3 TPE

Sensor profile SP manufactured without end caps.

Sensor profile (without control unit)	SK SP/W 17-3 TPE or SK SP/BK 17-3 TPE
Test principles	EN 12978, ISO 13849-1, ISO 13856-2
Switching characteristics at $v_{test} = 10 \text{ mm/s}$	
Switching operations	10,000
Actuation force	
Test piece Ø 20 mm	< 50 N
Test piece (cylinder) Ø 80 mm	< 150 N
Actuation distance	
Test piece (cylinder) Ø 80 mm	1.5 mm
Actuation angle	
Test piece (cylinder) Ø 80 mm	±45°
Finger detection	yes
Safety classifications	
ISO 13849-1: B _{10D}	2× 10 ⁶
Mechanical operating conditions	
Sensor length (min./max.)	10 cm / 80 m
Cable length (min./max.)	10 cm / 100 m
Bend radii, minimal	
B ₁ / B ₂ / B ₃ / B ₄	200 / 200 / 50 / 50 mm
Operating speed (min. / max.)	10 mm/s / 10 mm/s
max. load capacity (signal)	600 N
Tensile load, cable (max.)	20 N
IEC 60529: Degree of protection	IP67
Operating temperature	-25 to +55 °C
short-term (15 min)	-40 to +80 °C
Storage temperature	-40 to +80 °C
Weight	without/with Aluminium profile (Type)
SP 17-3	0.12 / 0.28 kg/m (C 15)
Electrical operating conditions	
Terminal resistance	8k2 ±1 %
Rated capacity (max.)	250 mW
Contact transition resistance	< 400 Ohm (per sensor)
Number of sensors type BK	max. 5 in series (for more in- formation refer to the chap- ter <i>Limits</i>)
Switching voltage (max.)	DC 24 V
Switching current (min. / max.)	1 mA / 10 mA
Connection cable	Ø 2.9 mm PUR 2× 0.25 mm ²

Bend radii:

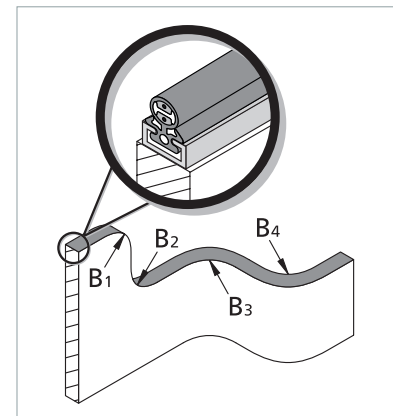

Dimensions and distances

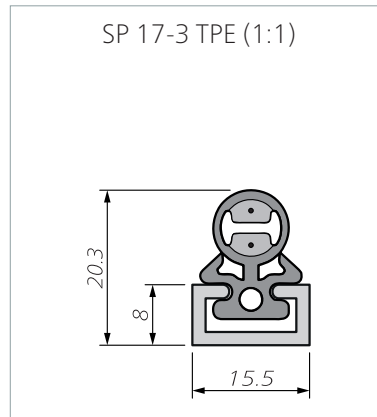

Dimensional tolerances according to ISO 3302 E2/L2.

Test conditions

according to ISO 13856-2

- Installation position B
- Temperature +20 °C
- Measurement point c3
- Test sample 1 with Ø 80 mm
- without control unit

All the data given here has been verified by Mayser GmbH & Co. KG.

Force-distance ratios

Test speed	10 mm/s
Actuation force	38 N
Response time	140 ms
Actuation distance (A)	1.4 mm
Overtravel distance	
up to 250 N (B1)	1.4 mm
up to 400 N (B2)	2.3 mm
up to 600 N (C)	4.1 mm
Total deformation	5.5 mm

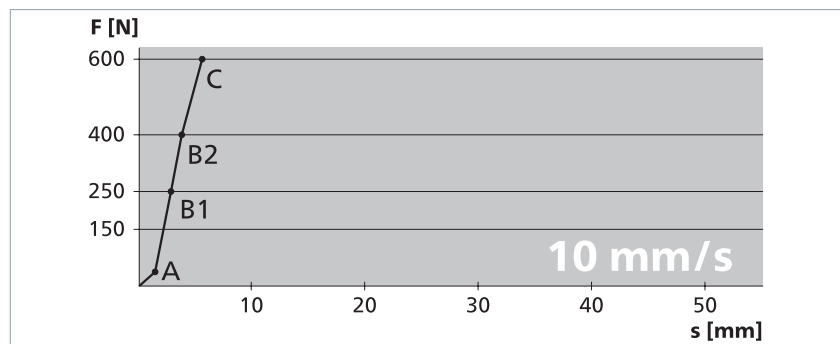

Technical data

SK SP 37-1 TPE

Sensor profile SP manufactured with or without end caps.

Sensor profile (without control unit)	SK SP/W 37-1 TPE or SK SP/BK 37-1 TPE
Test principles	EN 12978, ISO 13849-1, ISO 13856-2
Switching characteristics at $v_{test} = 100 \text{ mm/s}$	
Switching operations	10,000
Actuation force	
Test piece Ø 20 mm	< 50 N
Test piece (cylinder) Ø 80 mm	< 150 N
Actuation distance	
Test piece (cylinder) Ø 80 mm	6 mm
Actuation angle	
Test piece (cylinder) Ø 80 mm	±50°
Finger detection	yes
Safety classifications	
ISO 13849-1: B _{10D}	2× 10 ⁶
Mechanical operating conditions	
Sensor length (min./max.)	10 cm / 30 m
Cable length (min./max.)	10 cm / 100 m
Bend radii, minimal	
B ₁ / B ₂ / B ₃ / B ₄	500 / 500 / 200 / 200 mm
Operating speed	
(min. / max.)	10 mm/s / 200 mm/s
max. load capacity (signal)	600 N
Tensile load, cable (max.)	20 N
IEC 60529: Degree of protection	IP67
Operating temperature	
short-term (15 min)	-25 to +55 °C
Storage temperature	-40 to +80 °C
Weight	without/with Aluminium profile (Type)
SP 37-1	0.33 / 0.64 kg/m (C 25)
Electrical operating conditions	
Terminal resistance	8k2 ±1 %
Rated capacity (max.)	250 mW
Contact transition resistance	< 400 Ohm (per sensor)
Number of sensors type BK	max. 5 in series (for more in- formation refer to the chap- ter <i>Limits</i>)
Switching voltage (max.)	DC 24 V
Switching current (min. / max.)	1 mA / 10 mA
Connection cable	Ø 2.9 mm PUR 2× 0.25 mm ²

Bend radii:

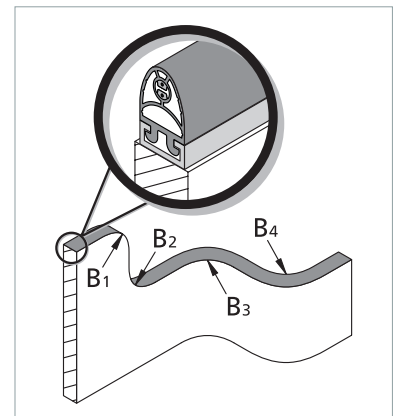

Dimensions and distances

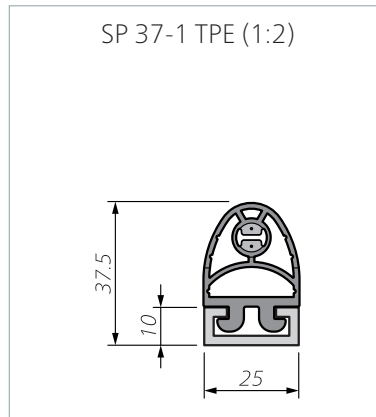

Dimensional tolerances according to ISO 3302 E2/L2.

Test conditions

according to ISO 13856-2

- Installation position B
- Temperature +20 °C
- Measurement point c3
- Test sample 1 with Ø 80 mm
- without control unit

All data stated here is documented in EC design type test certificates.

Force-distance ratios

Test speed	10 mm/s
Actuation force	42 N
Response time	580 ms
Actuation distance (A)	5.8 mm
Overtravel distance	
up to 250 N (B1)	9.2 mm
up to 400 N (B2)	11.1 mm
up to 600 N (C)	13.0 mm
Total deformation	18.8 mm

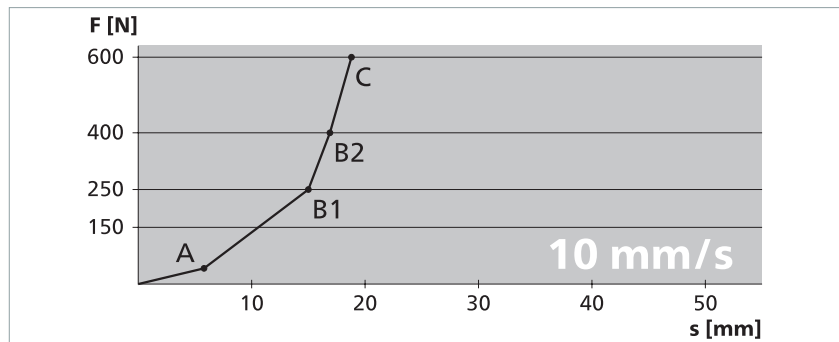

Test speed	100 mm/s
Actuation force	50 N
Response time	58 ms
Actuation distance (A)	5.8 mm
Overtravel distance	
up to 250 N (B1)	8.7 mm
up to 400 N (B2)	10.5 mm
up to 600 N (C)	12.5 mm
Total deformation	18.3 mm

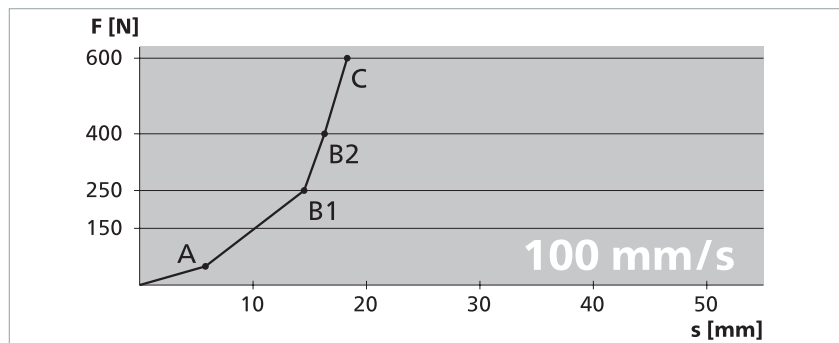

Test speed	200 mm/s
Actuation force	54 N
Response time	35 ms
Actuation distance (A)	7.0 mm
Overtravel distance	
up to 250 N (B1)	3.8 mm
up to 400 N (B2)	7.6 mm
up to 600 N (C)	12.9 mm
Total deformation	19.9 mm

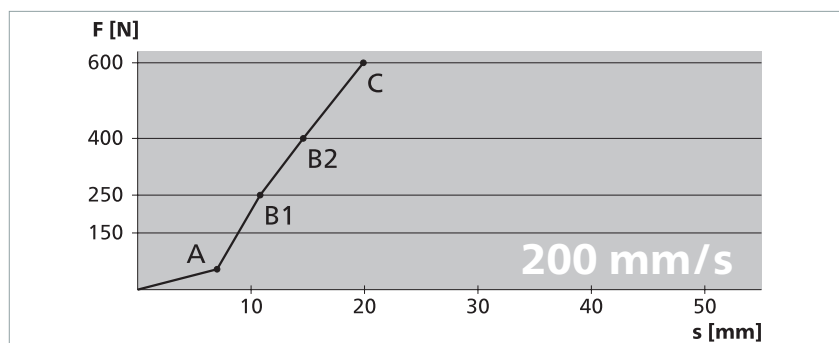

Technical data

SK SP 37(L)-2 TPE

Sensor profile SP manufactured with end caps.

Sensor profile (without control unit)	SK SP/W 37(L)-2 TPE or SK SP/BK 37(L)-2 TPE
Test principles	EN 12978, ISO 13849-1, ISO 13856-2
Switching characteristics at $v_{test} = 100 \text{ mm/s}$	
Switching operations	10,000
Actuation force	
Test piece Ø 20 mm	< 50 N
Test piece (cylinder) Ø 80 mm	< 150 N
Actuation distance	
Test piece (cylinder) Ø 80 mm	6 mm
Actuation angle	
Test piece (cylinder) Ø 80 mm	±50°
Finger detection	yes
Safety classifications	
ISO 13849-1: B _{10D}	2× 10 ⁶
Mechanical operating conditions	
Sensor length (min./max.)	10 cm / 30 m
Cable length (min./max.)	10 cm / 100 m
Bend radii, minimal	
B ₁ / B ₂ / B ₃ / B ₄	500 / 500 / 200 / 200 mm
Operating speed	
(min. / max.)	10 mm/s / 200 mm/s
max. load capacity (signal)	600 N
Tensile load, cable (max.)	20 N
IEC 60529: Degree of protection	IP67
Operating temperature	
short-term (15 min)	-25 to +55 °C
Storage temperature	-40 to +80 °C
Weight	without/with Aluminium profile (Type)
SP 37-2	0.36 / 0.69 kg/m (C 26)
SP 37L-2	0.41 / 0.74 kg/m (C 26)
Electrical operating conditions	
Terminal resistance	8k2 ±1 %
Rated capacity (max.)	250 mW
Contact transition resistance	< 400 Ohm (per sensor)
Number of sensors type BK	max. 5 in series (for more in- formation refer to the chap- ter <i>Limits</i>)
Switching voltage (max.)	DC 24 V
Switching current (min. / max.)	1 mA / 10 mA
Connection cable	Ø 2.9 mm PUR 2× 0.25 mm ²

Bend radii:

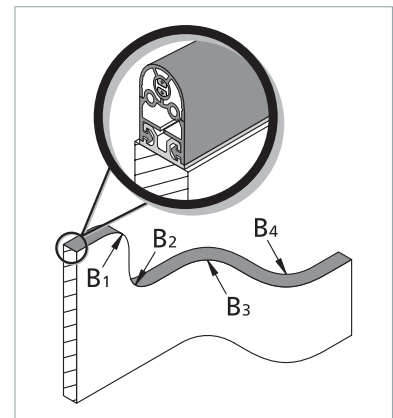

Dimensions and distances

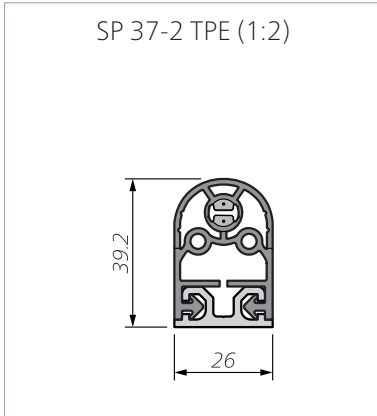

Dimensional tolerances according to ISO 3302 E2/L2.

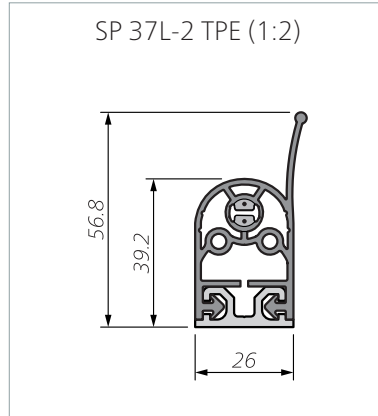

Dimensional tolerances according to ISO 3302 E2/L2.

Test conditions

according to ISO 13856-2

- Installation position B
- Temperature +20 °C
- Measurement point c3
- Test sample 1 with Ø 80 mm
- without control unit
- Lip not taken into account

All data stated here is documented in EC design type test certificates.

Force-distance ratios

Test speed	10 mm/s
Actuation force	42 N
Response time	580 ms
Actuation distance (A)	5.8 mm
Overtravel distance	
up to 250 N (B1)	9.2 mm
up to 400 N (B2)	11.1 mm
up to 600 N (C)	13.0 mm
Total deformation	18.8 mm

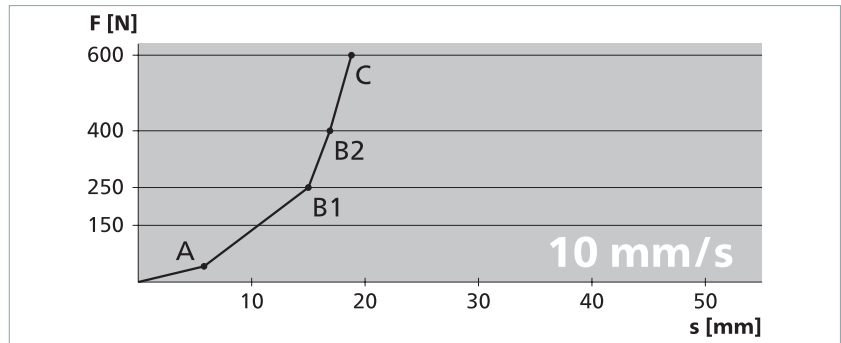

Test speed	100 mm/s
Actuation force	50 N
Response time	58 ms
Actuation distance (A)	5.8 mm
Overtravel distance	
up to 250 N (B1)	8.7 mm
up to 400 N (B2)	10.5 mm
up to 600 N (C)	12.5 mm
Total deformation	18.3 mm

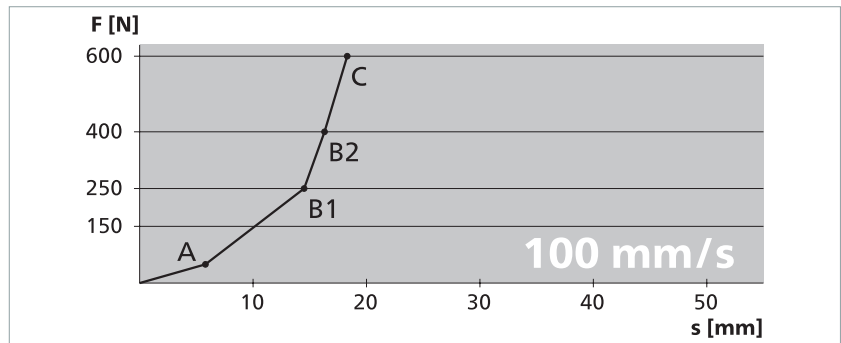

Test speed	200 mm/s
Actuation force	54 N
Response time	35 ms
Actuation distance (A)	7.0 mm
Overtravel distance	
up to 250 N (B1)	3.8 mm
up to 400 N (B2)	7.6 mm
up to 600 N (C)	12.9 mm
Total deformation	19.9 mm

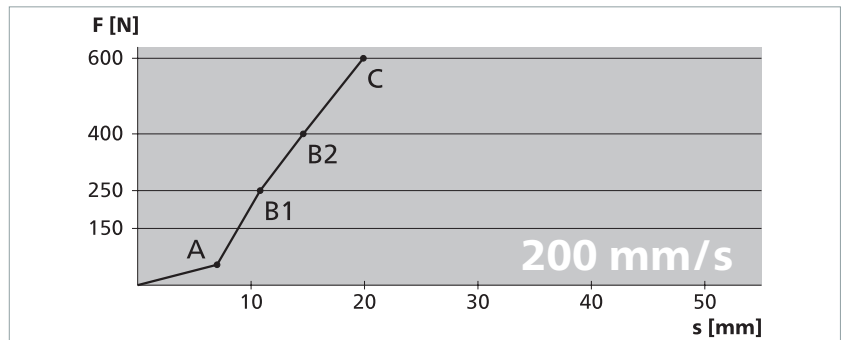

Technical data

SK SP 37-3 TPE

Sensor profile SP manufactured with end caps.

Sensor profile (without control unit)	SK SP/W 37-3 TPE or SK SP/BK 37-3 TPE
Test principles	EN 12978, ISO 13849-1, ISO 13856-2
Switching characteristics at $v_{test} = 100 \text{ mm/s}$	
Switching operations	10,000
Actuation force	
Test piece Ø 20 mm	< 50 N
Test piece (cylinder) Ø 80 mm	< 150 N
Actuation distance	
Test piece (cylinder) Ø 80 mm	6 mm
Actuation angle	
Test piece (cylinder) Ø 80 mm	±50°
Finger detection	yes
Safety classifications	
ISO 13849-1: B _{10D}	2× 10 ⁶
Mechanical operating conditions	
Sensor length (min./max.)	10 cm / 30 m
Cable length (min./max.)	10 cm / 100 m
Bend radii, minimal	
B ₁ / B ₂ / B ₃ / B ₄	500 / 500 / 200 / 200 mm
Operating speed	
(min. / max.)	10 mm/s / 200 mm/s
max. load capacity (signal)	600 N
Tensile load, cable (max.)	20 N
IEC 60529: Degree of protection	IP67
Operating temperature	
short-term (15 min)	-25 to +55 °C
Storage temperature	-40 to +80 °C
Weight	
SP 37-3	without/with Aluminium profile (Type) 0.34 / 0.66 kg/m (C 25)
Electrical operating conditions	
Terminal resistance	8k2 ±1 %
Rated capacity (max.)	250 mW
Contact transition resistance	< 400 Ohm (per sensor)
Number of sensors type BK	max. 5 in series (for more in- formation refer to the chap- ter <i>Limits</i>)
Switching voltage (max.)	DC 24 V
Switching current (min. / max.)	1 mA / 10 mA
Connection cable	Ø 2.9 mm PUR 2× 0.25 mm ²

Bend radii:

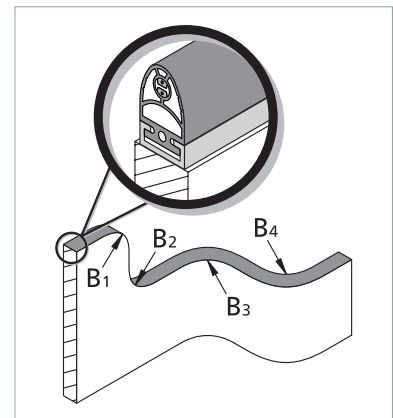

Dimensions and distances

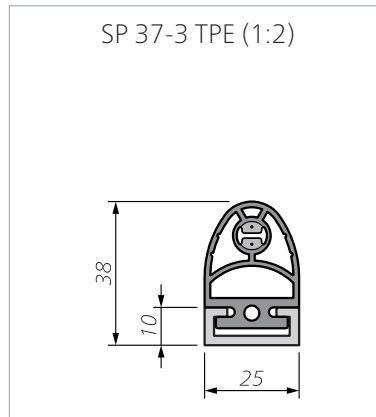

Dimensional tolerances according to ISO 3302 E2/L2.

Test conditions

according to ISO 13856-2

- Installation position B
- Temperature +20 °C
- Measurement point c3
- Test sample 1 with Ø 80 mm
- without control unit

All data stated here is documented in EC design type test certificates.

Force-distance ratios

Test speed	10 mm/s
Actuation force	42 N
Response time	580 ms
Actuation distance (A)	5.8 mm
Overtravel distance	
up to 250 N (B1)	9.2 mm
up to 400 N (B2)	11.1 mm
up to 600 N (C)	13.0 mm
Total deformation	18.8 mm

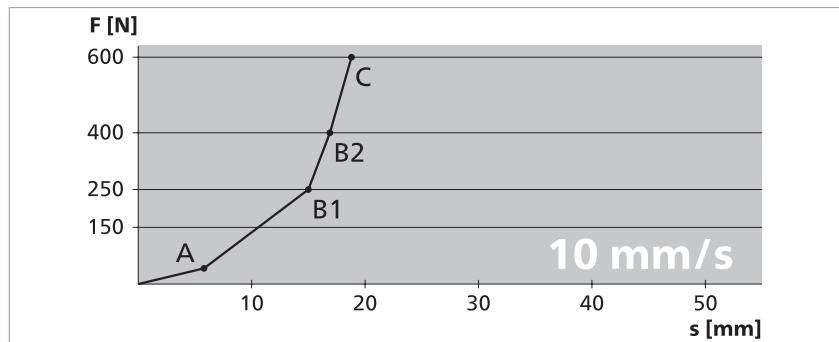

Test speed	100 mm/s
Actuation force	50 N
Response time	58 ms
Actuation distance (A)	5.8 mm
Overtravel distance	
up to 250 N (B1)	8.7 mm
up to 400 N (B2)	10.5 mm
up to 600 N (C)	12.5 mm
Total deformation	18.3 mm

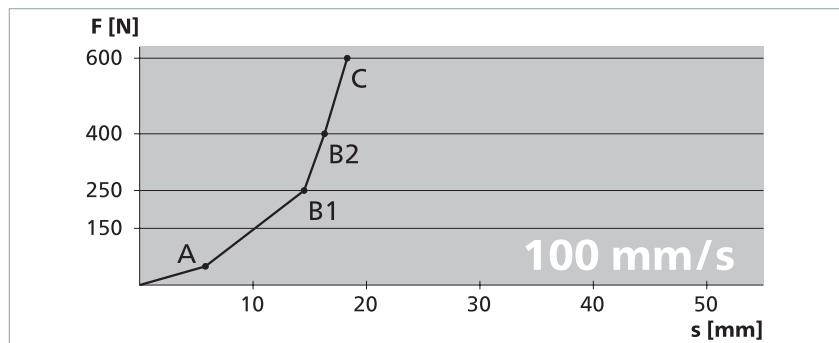

Test speed	200 mm/s
Actuation force	54 N
Response time	35 ms
Actuation distance (A)	7.0 mm
Overtravel distance	
up to 250 N (B1)	3.8 mm
up to 400 N (B2)	7.6 mm
up to 600 N (C)	12.9 mm
Total deformation	19.9 mm

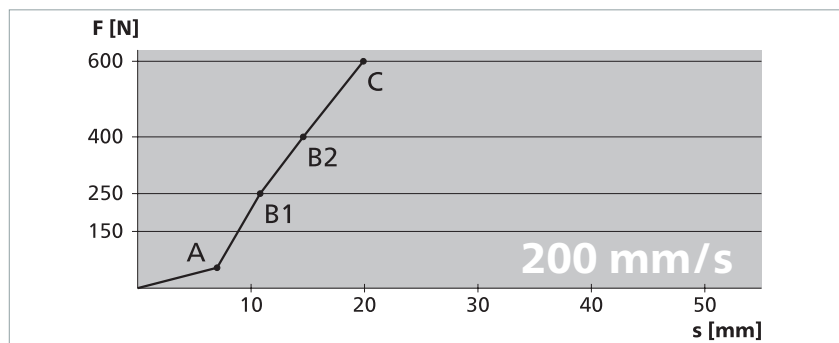

Technical data

SK SP 57(L)-2 TPE

Sensor profile SP manufactured with end caps.

Sensor profile (without control unit)	SK SP/W 57(L)-2 TPE or SK SP/BK 57(L)-2 TPE
Test principles	EN 12978, ISO 13849-1, ISO 13856-2
Switching characteristics at $v_{test} = 100 \text{ mm/s}$	
Switching operations	10,000
Actuation force	
Test piece Ø 20 mm	< 50 N
Test piece (cylinder) Ø 80 mm	< 150 N
Actuation distance	
Test piece (cylinder) Ø 80 mm	8 mm
Actuation angle	
Test piece (cylinder) Ø 80 mm	±45°
Finger detection	yes
Safety classifications	
ISO 13849-1: B _{10D}	2× 10 ⁶
Mechanical operating conditions	
Sensor length (min./max.)	10 cm / 30 m
Cable length (min./max.)	10 cm / 100 m
Bend radii, minimal	
B ₁ / B ₂ / B ₃ / B ₄	1000 / 1000 / 200 / 200 mm
Operating speed	
(min. / max.)	10 mm/s / 200 mm/s
max. load capacity (signal)	600 N
Tensile load, cable (max.)	20 N
IEC 60529: Degree of protection	IP67
Operating temperature	
short-term (15 min)	-25 to +55 °C
Storage temperature	-40 to +80 °C
Weight	without/with Aluminium profile (Type)
SP 57-2	0.44 / 0.74 kg/m (C 30)
SP 57L-2	0.47 / 0.77 kg/m (C 30)
Electrical operating conditions	
Terminal resistance	8k2 ±1 %
Rated capacity (max.)	250 mW
Contact transition resistance	< 400 Ohm (per sensor)
Number of sensors type BK	max. 5 in series (for more in- formation refer to the chap- ter <i>Limits</i>)
Switching voltage (max.)	DC 24 V
Switching current (min. / max.)	1 mA / 10 mA
Connection cable	Ø 2.9 mm PUR 2× 0.25 mm ²

Bend radii:

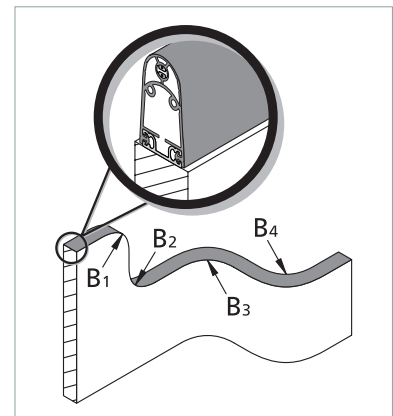

Dimensions and distances

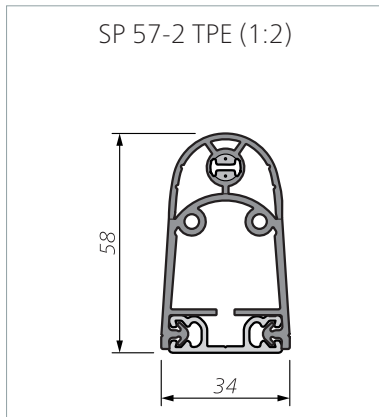

Dimensional tolerances according to ISO 3302 E2/L2.

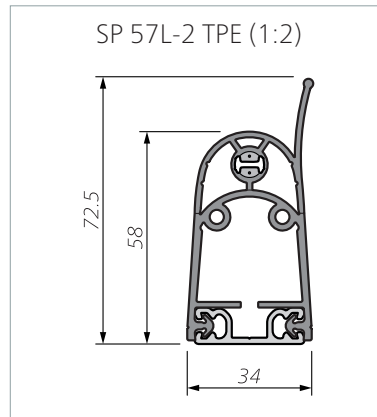

Dimensional tolerances according to ISO 3302 E2/L2.

Test conditions

according to ISO 13856-2

- Installation position B
- Temperature +20 °C
- Measurement point c3
- Test sample 1 with Ø 80 mm
- without control unit
- Lip not taken into account

All data stated here is documented in EC design type test certificates.

Force-distance ratios

Test speed	10 mm/s
Actuation force	48 N
Response time	910 ms
Actuation distance (A)	9.1 mm
Overtravel distance	
up to 250 N (B1)	24.5 mm
up to 400 N (B2)	29.3 mm
up to 600 N (C)	31.0 mm
Total deformation	40.1 mm

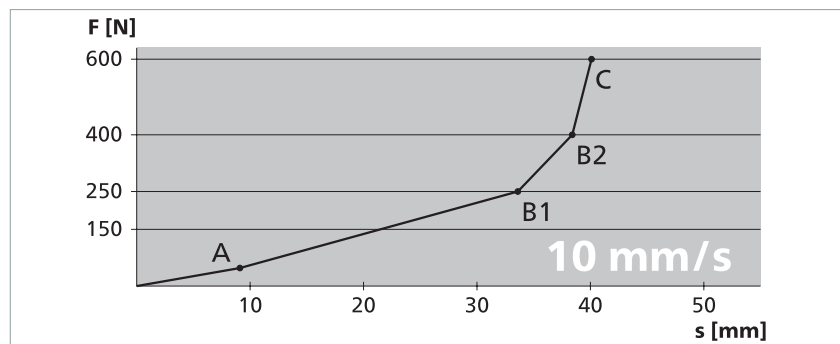

Test speed	100 mm/s
Actuation force	41 N
Response time	80 ms
Actuation distance (A)	8.0 mm
Overtravel distance	
up to 250 N (B1)	26.0 mm
up to 400 N (B2)	29.4 mm
up to 600 N (C)	31.5 mm
Total deformation	39.5 mm

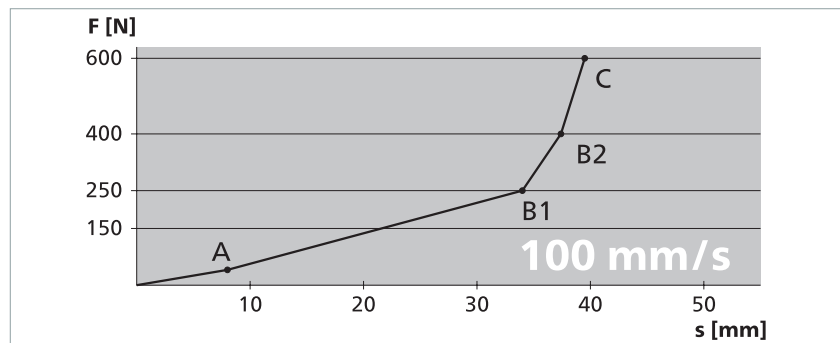

Test speed	200 mm/s
Actuation force	58 N
Response time	71 ms
Actuation distance (A)	14.2 mm
Overtravel distance	
up to 250 N (B1)	20.8 mm
up to 400 N (B2)	23.7 mm
up to 600 N (C)	25.9 mm
Total deformation	40.1 mm

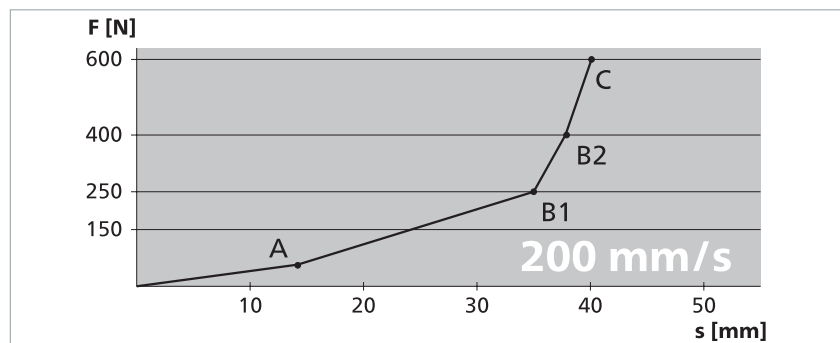

Technical data

SK SP 57-3 TPE

Sensor profile SP manufactured with end caps.

Sensor profile (without control unit)	SK SP/W 57-3 TPE or SK SP/BK 57-3 TPE
Test principles	EN 12978, ISO 13849-1, ISO 13856-2
Switching characteristics at $v_{test} = 100 \text{ mm/s}$	
Switching operations	10,000
Actuation force	
Test piece Ø 20 mm	< 50 N
Test piece (cylinder) Ø 80 mm	< 150 N
Actuation distance	
Test piece (cylinder) Ø 80 mm	8 mm
Actuation angle	
Test piece (cylinder) Ø 80 mm	$\pm 45^\circ$
Finger detection	yes
Safety classifications	
ISO 13849-1: B _{10D}	2×10^6
Mechanical operating conditions	
Sensor length (min./max.)	10 cm / 25 m
Cable length (min./max.)	10 cm / 100 m
Bend radii, minimal	
B ₁ / B ₂ / B ₃ / B ₄	1000 / 1000 / 200 / 200 mm
Operating speed	
(min. / max.)	10 mm/s / 200 mm/s
max. load capacity (signal)	600 N
Tensile load, cable (max.)	20 N
IEC 60529: Degree of protection	IP67
Operating temperature	
short-term (15 min)	-25 to +55 °C
Storage temperature	-40 to +80 °C
Weight	
SP 57-3	without/with Aluminium profile (Type) 0.60 / 1.00 kg/m (C 35)
Electrical operating conditions	
Terminal resistance	8k2 ±1 %
Rated capacity (max.)	250 mW
Contact transition resistance	< 400 Ohm (per sensor)
Number of sensors type BK	max. 5 in series (for more in- formation refer to the chap- ter <i>Limits</i>)
Switching voltage (max.)	DC 24 V
Switching current (min. / max.)	1 mA / 10 mA
Connection cable	Ø 2.9 mm PUR 2× 0.25 mm ²

Bend radii:

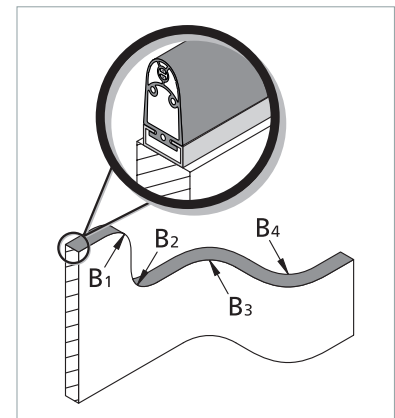

Dimensions and distances

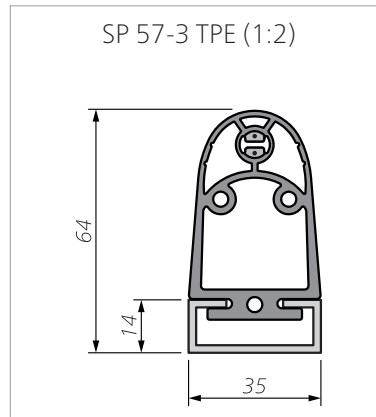

Dimensional tolerances according to ISO 3302 E2/L2.

Test conditions

according to ISO 13856-2

- Installation position B
- Temperature +20 °C
- Measurement point c3
- Test sample 1 with Ø 80 mm
- without control unit

All data stated here is documented in EC design type test certificates.

Force-distance ratios

Test speed	10 mm/s
Actuation force	48 N
Response time	910 ms
Actuation distance (A)	9.1 mm
Overtravel distance	
up to 250 N (B1)	24.5 mm
up to 400 N (B2)	29.3 mm
up to 600 N (C)	31.0 mm
Total deformation	40.1 mm

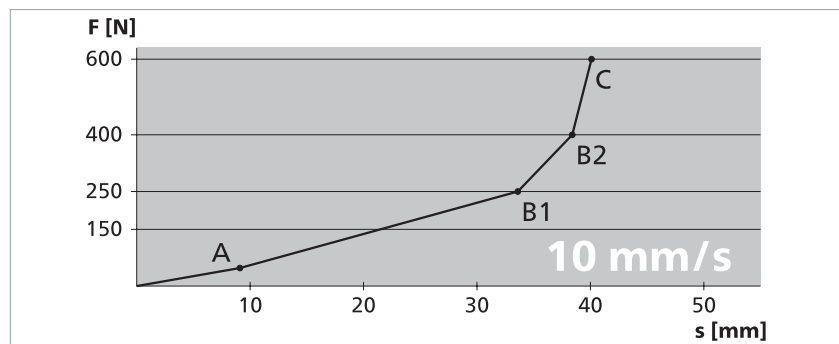

Test speed	100 mm/s
Actuation force	41 N
Response time	80 ms
Actuation distance (A)	8.0 mm
Overtravel distance	
up to 250 N (B1)	26.0 mm
up to 400 N (B2)	29.4 mm
up to 600 N (C)	31.5 mm
Total deformation	39.5 mm

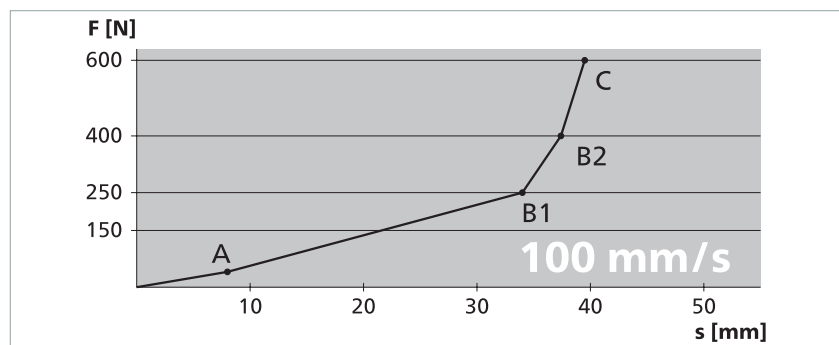

Test speed	200 mm/s
Actuation force	58 N
Response time	71 ms
Actuation distance (A)	14.2 mm
Overtravel distance	
up to 250 N (B1)	20.8 mm
up to 400 N (B2)	23.7 mm
up to 600 N (C)	25.9 mm
Total deformation	40.1 mm

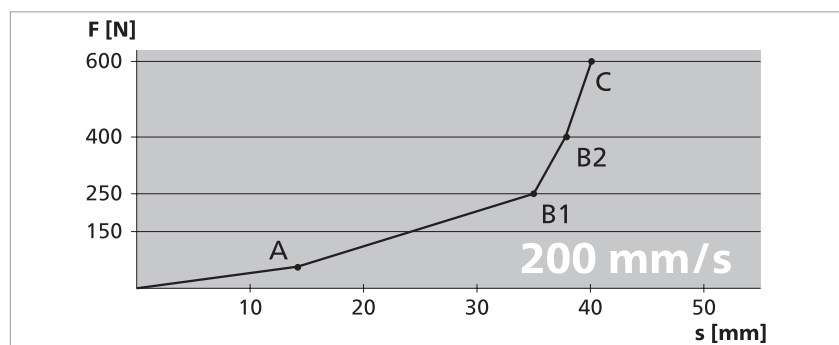

Technical data

SK SP 57(L)-4 TPE

Sensor profile SP manufactured with end caps.

Sensor profile (without control unit)	SK SP/W 57(L)-4 TPE or SK SP/BK 57(L)-4 TPE
Test principles	EN 12978, ISO 13849-1, ISO 13856-2
Switching characteristics at $v_{test} = 100 \text{ mm/s}$	
Switching operations	10,000
Actuation force	
Test piece Ø 20 mm	< 50 N
Test piece (cylinder) Ø 80 mm	< 150 N
Actuation distance	
Test piece (cylinder) Ø 80 mm	8 mm
Actuation angle	
Test piece (cylinder) Ø 80 mm	±45°
Finger detection	yes
Safety classifications	
ISO 13849-1: B _{10D}	2× 10 ⁶
Mechanical operating conditions	
Sensor length (min./max.)	10 cm / 25 m
Cable length (min./max.)	10 cm / 100 m
Bend radii, minimal	
B ₁ / B ₂ / B ₃ / B ₄	1000 / 1000 / 200 / 200 mm
Operating speed	
(min. / max.)	10 mm/s / 200 mm/s
max. load capacity (signal)	600 N
Tensile load, cable (max.)	20 N
IEC 60529: Degree of protection	IP67
Operating temperature	
short-term (15 min)	-25 to +55 °C
Storage temperature	-40 to +80 °C
Weight	without/with Aluminium profile (Type)
SP 57-4	0.58 / 0.99 kg/m (C 35)
SP 57L-4	0.62 / 1.03 kg/m (C 35)
Electrical operating conditions	
Terminal resistance	8k2 ±1 %
Rated capacity (max.)	250 mW
Contact transition resistance	< 400 Ohm (per sensor)
Number of sensors type BK	max. 5 in series (for more in- formation refer to the chap- ter <i>Limits</i>)
Switching voltage (max.)	DC 24 V
Switching current (min. / max.)	1 mA / 10 mA
Connection cable	Ø 2.9 mm PUR 2× 0.25 mm ²

Bend radii:

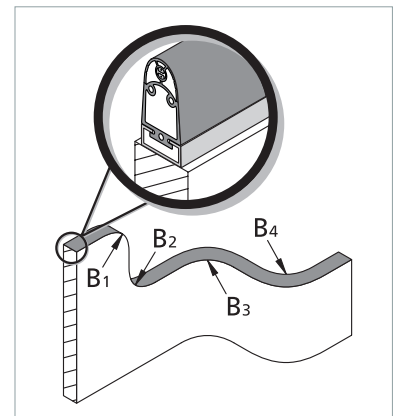

Dimensions and distances

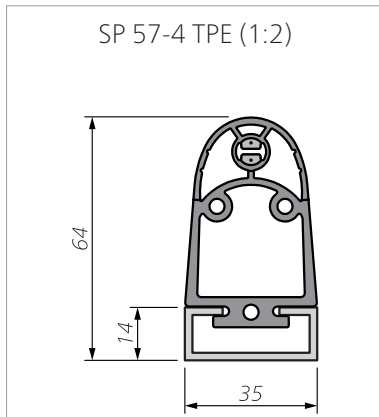

Dimensional tolerances according to ISO 3302 E2/L2.

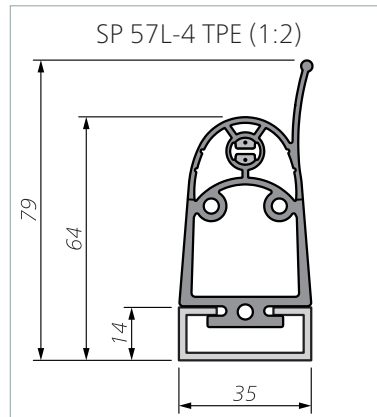

Dimensional tolerances according to ISO 3302 E2/L2.

Test conditions

according to ISO 13856-2

- Installation position B
- Temperature +20 °C
- Measurement point c3
- Test sample 1 with Ø 80 mm
- without control unit
- Lip not taken into account

All data stated here is documented in EC design type test certificates.

Force-distance ratios

Test speed	10 mm/s
Actuation force	48 N
Response time	910 ms
Actuation distance (A)	9.1 mm
Overtravel distance	
up to 250 N (B1)	24.5 mm
up to 400 N (B2)	29.3 mm
up to 600 N (C)	31.0 mm
Total deformation	40.1 mm

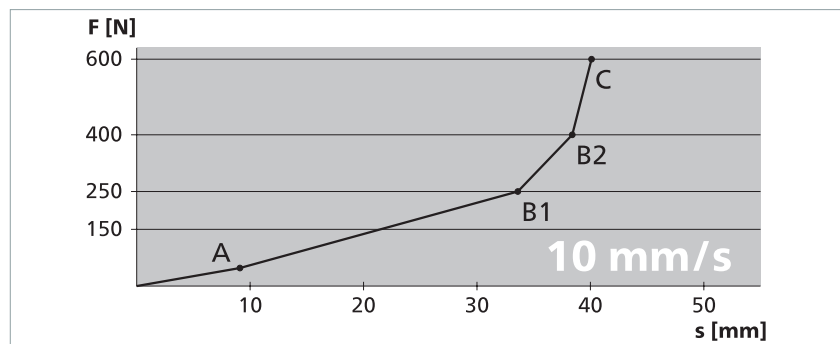

Test speed	100 mm/s
Actuation force	41 N
Response time	80 ms
Actuation distance (A)	8.0 mm
Overtravel distance	
up to 250 N (B1)	26.0 mm
up to 400 N (B2)	29.4 mm
up to 600 N (C)	31.5 mm
Total deformation	39.5 mm

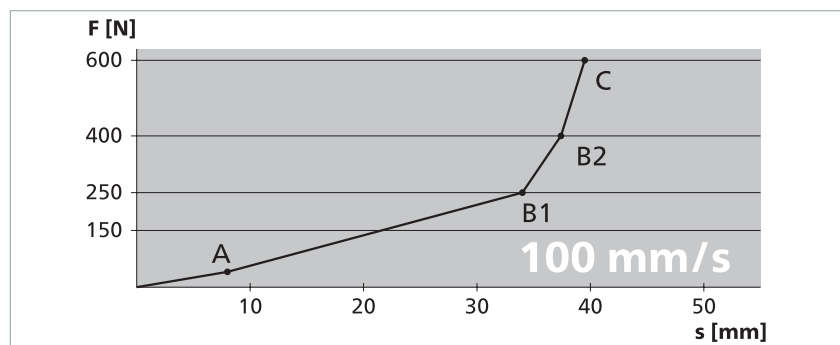

Test speed	200 mm/s
Actuation force	58 N
Response time	71 ms
Actuation distance (A)	14.2 mm
Overtravel distance	
up to 250 N (B1)	20.8 mm
up to 400 N (B2)	23.7 mm
up to 600 N (C)	25.9 mm
Total deformation	40.1 mm

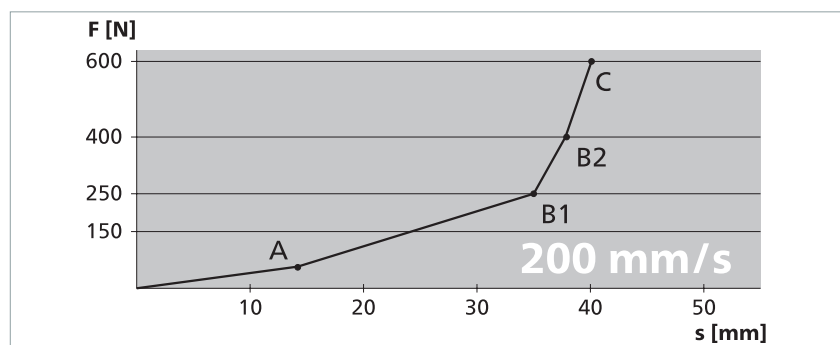

Technical data

SK SP 67-2 TPE

Sensor profile SP manufactured with end caps.

Sensor profile (without control unit)	SK SP/W 67-2 TPE or SK SP/BK 67-2 TPE
Test principles	EN 12978, ISO 13849-1, ISO 13856-2
Switching characteristics at $v_{test} = 100 \text{ mm/s}$	
Switching operations	10,000
Actuation force	
Test piece Ø 20 mm	< 50 N
Test piece (cylinder) Ø 80 mm	< 150 N
Actuation distance	
Test piece (cylinder) Ø 80 mm	11 mm
Actuation angle	
Test piece (cylinder) Ø 80 mm	$\pm 45^\circ$
Finger detection	yes
Safety classifications	
ISO 13849-1: B _{10D}	2×10^6
Mechanical operating conditions	
Sensor length (min./max.)	10 cm / 30 m
Cable length (min./max.)	10 cm / 100 m
Bend radii, minimal	
B ₁ / B ₂ / B ₃ / B ₄	1000 / 1000 / 200 / 200 mm
Operating speed	
(min. / max.)	10 mm/s / 200 mm/s
max. load capacity (signal)	600 N
Tensile load, cable (max.)	20 N
IEC 60529: Degree of protection	IP67
Operating temperature	
short-term (15 min)	-25 to +55 °C
Storage temperature	-40 to +80 °C
Weight	
SP 67-2	without/with Aluminium profile (Type) 0.49 / 0.79 kg/m (C 30)
Electrical operating conditions	
Terminal resistance	$8k2 \pm 1 \%$
Rated capacity (max.)	250 mW
Contact transition resistance	< 400 Ohm (per sensor)
Number of sensors type BK	max. 5 in series (for more in- formation refer to the chap- ter <i>Limits</i>)
Switching voltage (max.)	DC 24 V
Switching current (min. / max.)	1 mA / 10 mA
Connection cable	Ø 2.9 mm PUR 2x 0.25 mm ²

Bend radii:

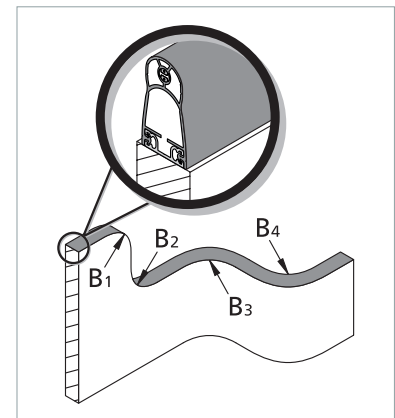

Dimensions and distances

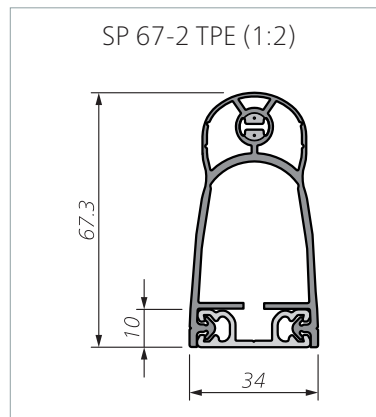

Dimensional tolerances according to ISO 3302 E2/L2.

Test conditions

according to ISO 13856-2

- Installation position B
- Temperature +20 °C
- Measurement point c3
- Test sample 1 with Ø 80 mm
- without control unit

All data stated here is documented in EC design type test certificates.

Force-distance ratios

Test speed	10 mm/s
Actuation force	41 N
Response time	880 ms
Actuation distance (A)	8.8 mm
Overtravel distance	
up to 250 N (B1)	35.7 mm
up to 400 N (B2)	37.9 mm
up to 600 N (C)	41 mm
Total deformation	49.8 mm

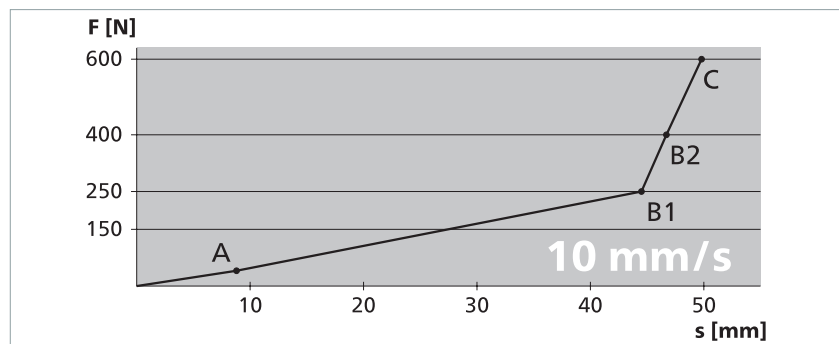

Test speed	100 mm/s
Actuation force	43 N
Response time	101 ms
Actuation distance (A)	10.1 mm
Overtravel distance	
up to 250 N (B1)	35.4 mm
up to 400 N (B2)	37.8 mm
up to 600 N (C)	39.8 mm
Total deformation	49.9 mm

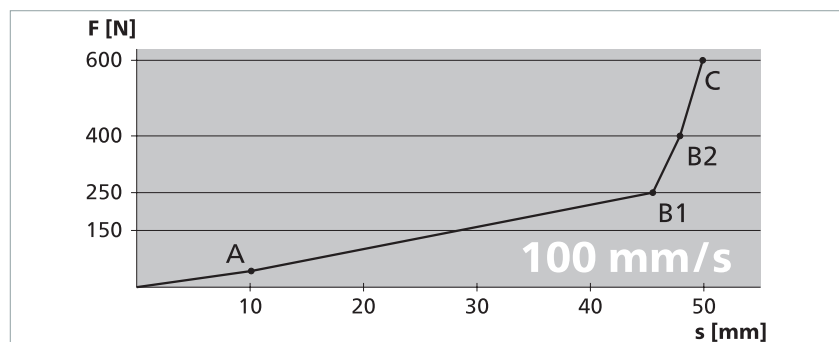

Test speed	200 mm/s
Actuation force	45 N
Response time	51.5 ms
Actuation distance (A)	10.3 mm
Overtravel distance	
up to 250 N (B1)	36.5 mm
up to 400 N (B2)	39.4 mm
up to 600 N (C)	41.3 mm
Total deformation	51.6 mm

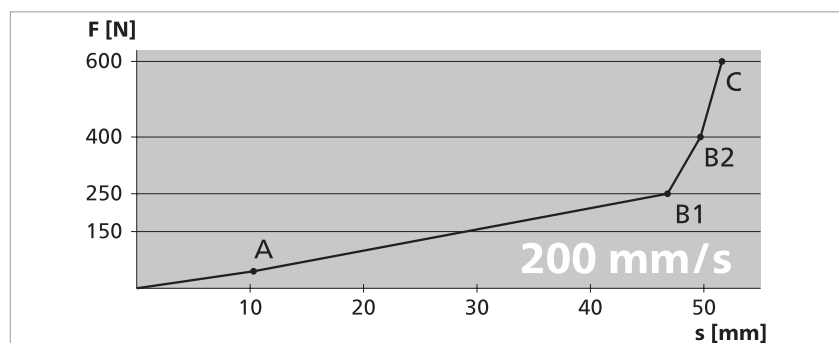

Technical data

SK SP 87-2 TPE

Sensor profile SP manufactured with end caps.

Sensor profile (without control unit)	SK SP/W 87-2 TPE or SK SP/BK 87-2 TPE
Test principles	EN 12978, ISO 13849-1, ISO 13856-2
Switching characteristics at $v_{test} = 100 \text{ mm/s}$	
Switching operations	10,000
Actuation force	
Test piece Ø 20 mm	< 50 N
Test piece (cylinder) Ø 80 mm	< 150 N
Actuation distance	
Test piece (cylinder) Ø 80 mm	9 mm
Actuation angle	
Test piece (cylinder) Ø 80 mm	$\pm 45^\circ$
Finger detection	yes
Safety classifications	
ISO 13849-1: B _{10D}	2×10^6
Mechanical operating conditions	
Sensor length (min./max.)	10 cm / 25 m
Cable length (min./max.)	10 cm / 100 m
Bend radii, minimal	
B ₁ / B ₂ / B ₃ / B ₄	1000 / 1000 / 200 / 200 mm
Operating speed	
(min. / max.)	10 mm/s / 200 mm/s
max. load capacity (signal)	600 N
Tensile load, cable (max.)	20 N
IEC 60529: Degree of protection	IP67
Operating temperature	
short-term (15 min)	-25 to +55 °C
Storage temperature	-40 to +80 °C
Weight	
SP 87-2	without/with Aluminium profile (Type) 0.64 / 1.06 kg/m (C 36)
Electrical operating conditions	
Terminal resistance	$8k2 \pm 1 \%$
Rated capacity (max.)	250 mW
Contact transition resistance	< 400 Ohm (per sensor)
Number of sensors type BK	max. 5 in series (for more in- formation refer to the chap- ter <i>Limits</i>)
Switching voltage (max.)	DC 24 V
Switching current (min. / max.)	1 mA / 10 mA
Connection cable	Ø 2.9 mm PUR 2x 0.25 mm ²

Bend radii:

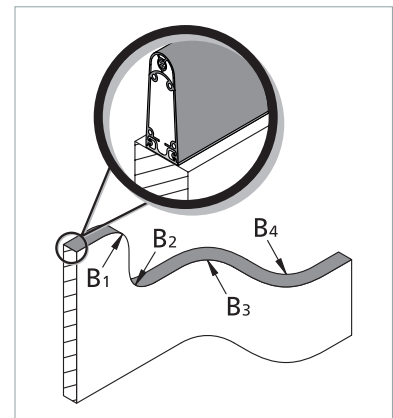

Dimensions and distances

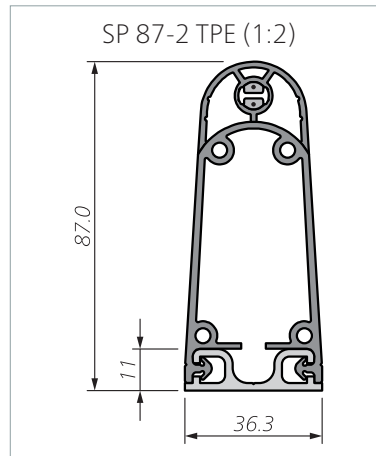

Dimensional tolerances according to ISO 3302 E2/L2.

Test conditions

according to ISO 13856-2

- Installation position B
- Temperature +20 °C
- Measurement point c3
- Test sample 1 with Ø 80 mm
- without control unit

All data stated here is documented in EC design type test certificates.

Force-distance ratios

Test speed	10 mm/s
Actuation force	34 N
Response time	850 ms
Actuation distance (A)	8.5 mm
Overtravel distance	
up to 250 N (B1)	52.3 mm
up to 400 N (B2)	54.7 mm
up to 600 N (C)	56.2 mm
Total deformation	64.7 mm

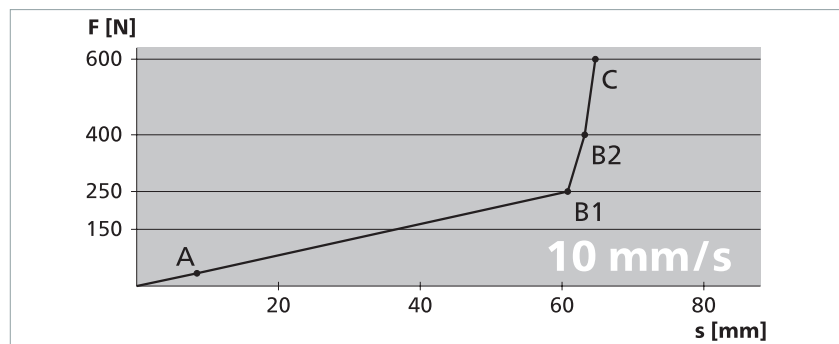

Test speed	100 mm/s
Actuation force	38 N
Response time	81 ms
Actuation distance (A)	8.1 mm
Overtravel distance	
up to 250 N (B1)	51.9 mm
up to 400 N (B2)	54.4 mm
up to 600 N (C)	56.0 mm
Total deformation	64.1 mm

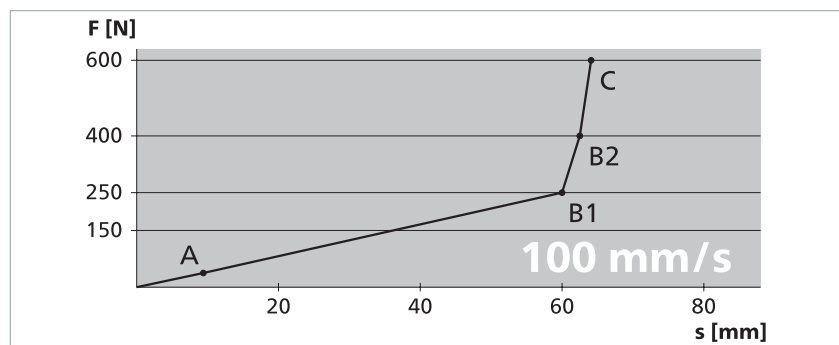

Test speed	200 mm/s
Actuation force	37 N
Response time	47 ms
Actuation distance (A)	9.4 mm
Overtravel distance	
up to 250 N (B1)	51.5 mm
up to 400 N (B2)	54.0 mm
up to 600 N (C)	55.5 mm
Total deformation	64.9 mm

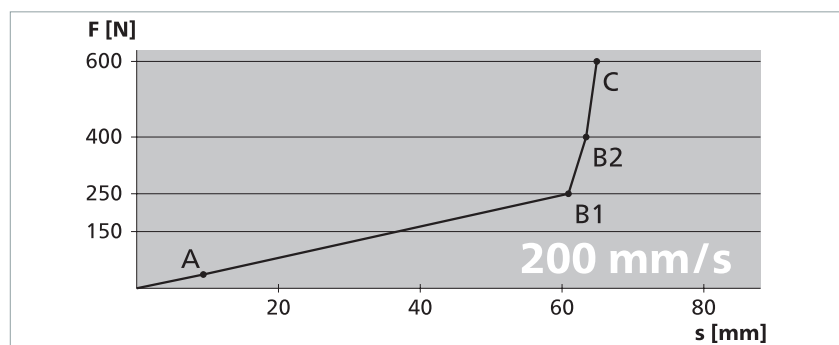

Marking

If you combine sensors with control units and thereby release pressure-sensitive safeguards onto the market, observe the basic regulations in ISO 13856.

Apart from technical requirements, this applies in particular also to marking and information for use.

Conformity

EC design test

The product was tested by an independent institute.

An EC design type test certificate confirms conformity.

The EC design type test certificate is available in the download section of the website: www.mayser.com.

UL certification

The design type of the product complies with the basic requirements of UL certification:

- UL 325

